



## NPC Series Hardware User Manual

# Revision History

The version of the manual is also indicated on the bottom of the front cover.

MB02UE01-2603\_V1.0 (Original instructions)

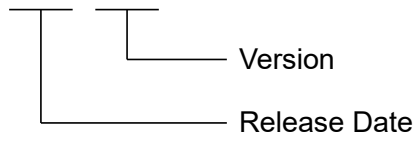

Release Date	Version	Applicable Product	Revision Contents
Mar. 31 <sup>st</sup> , 2026	1.0	NPC series	First edition.

## Related Documents



Through related documents, users can quickly understand the positioning of this manual and the correlation between manuals and products. Go to HIWIN MIKROSYSTEM's official website → Download → Manual Overview for details ([https://www.hiwinmikro.tw/Downloads/ManualOverview\\_EN.htm](https://www.hiwinmikro.tw/Downloads/ManualOverview_EN.htm)).

## **Preface**

This manual aims to assist users to operate NPC series (NPC for short). The contents in this manual, including manual preface, model explanation, evaluation of mechanism design and precautions for electrical planning, are arranged in accordance with the procedure of configuring a machine. Carefully read through this manual to correctly operate NPC.

# Approvals

Approvals		
Integration Standards	EU Directives	
	EMC Directives	EN IEC 61800-3: 2023 (Category C3)
	Low-voltage Directives	EN IEC 61800-5-1: 2023 (PD2, OVC III at < 2000M)
	UL Approval	
	UL Standards	UL 61800-5-1; CSA C22.2 No. 274

NPC Model	EU Directives		UL Approval	<b>SEMI F47</b>
		<b>RoHS</b>		
NPC-X-A□-D□ Series	✓	✓	✓	✓
NPC-X-A□-A□ Series	✓	✓	✓	✓

Note:

EN: Europäischen Normen = European standard

CE refers to European standards.

(Publication of harmonised standards under Union harmonisation legislation)

IEC: International Electrotechnical Commission

UL: Underwriters Laboratories Inc.

The Certificate and the Declaration of Conformity can be downloaded from the official website of HIWIN MIKROSYSTEM CORP. (<https://www.hiwinmikro.tw/en/download>).

# General Precautions

Before using the product, please carefully read through this manual, the safety instructions, and the related manuals. If users do not have the manuals for the product, please contact HIWIN MIKROSYSTEM or local distributors and ensure the personnel responsible for the safe operation of the product have obtained these documents. If users cannot fully understand the manuals in the available language, please contact HIWIN MIKROSYSTEM or local distributors. HIWIN MIKROSYSTEM is not responsible for any damage, accident or injury caused by failure in following the installation instructions and operating instructions stated in this manual.

- Do not disassemble or modify the product. The design of the product has been verified by structural calculation, computer simulation and actual testing. HIWIN MIKROSYSTEM is not responsible for any damage, accident or injury caused by disassembly or modification done by users.
- Before installing or using the product, ensure there is no damage on its appearance. If any damage is found after inspection, please contact HIWIN MIKROSYSTEM or local distributors.
- Carefully read through the specification noted on the product label or technical document. Install the product according to its specification and installation instructions stated in this manual.
- Ensure the product is used with the power supply specified on the product label or in the product requirement. HIWIN MIKROSYSTEM is not responsible for any damage, accident or injury caused by using incorrect power supply.
- Ensure the product is used with the rated load. HIWIN MIKROSYSTEM is not responsible for any damage, accident or injury caused by improper usage.
- Only use accessories and spare parts approved by HIWIN MIKROSYSTEM.
- Commissioning of the product is only allowed once it is sure that the machine or system for product installation complies with the national regulations, safety specifications, and standards of the application.
- Do not subject the product to shock. HIWIN MIKROSYSTEM is not responsible for any damage, accident or injury caused by improper usage.
- Only qualified persons may work with components of the electric drive and control system or within its proximity.
- Until the integrated monitoring functions be executed, it must be assumed that faulty drive movements may occur in any case.
- If an error occurs in NPC, please refer to the related manual and follow the instructions for troubleshooting. After the error is cleared, power on NPC again.
- Do not repair the product by themselves when it malfunctions. The product can only be repaired by qualified technician from HIWIN MIKROSYSTEM.

HIWIN MIKROSYSTEM offers 1-year warranty for the product. The warranty does not cover damage caused by improper usage (refer to the precautions and instructions stated in this manual.) or natural disaster.

## CAUTION

- ◆ National regulations that users must comply with.
  - European countries: European standards (EN)
  - United States of America (USA):
    - National Electrical Code (NEC)
    - National Electrical Manufacturers Association (NEMA) and local engineering regulations
    - Regulations of the National Fire Protection Association (NFPA)
  - Canada: Canadian Standards Association (CSA)
  - Other countries:
    - International Organization for Standardization (ISO)
    - International Electrotechnical Commission (IEC)

- ◆ NPC DC series with rated input voltage DC 24 V ~ 100 V; AC series with rated input voltage AC 100 V ~ 240 V:





- (1) The maximum ambient temperature must be below 40 °C.
- (2) The product can only be installed in an environment with pollution degree not exceeding 2.
- (3) Before inspection, please turn off the power and wait for at least 15 minutes. To avoid electric shock, ensure the residual voltage between P and N terminals has dropped to 50 V<sub>DC</sub> or lower by using multimeter.
- (4) Follow the safety regulations and requirements of the country in which the product is operated.
- (5) Operation is only allowed if the national EMC regulations for the application are met.
- (6) The short circuit protection for internal circuits does not support branch circuit protection. Branch circuit protection must be implemented in accordance with the National Electrical Code and any additional local codes. Refer to the table below for the suggested fuses or circuit breakers used in DC series main input power (DC+, DC-) and AC series main input power (L1, L2, L3) of NPC.





NPC Model	Suggested Model	BCP Fuse Class	BCP Fuse Rating	Circuit Breaker	Interrupting Capacity
NPC-X-A□-D□ Series	Littelfuse / JLLN060.T	Class T	DC 160 V, 60 A	60 A	10 kA
NPC-X-A□-A□ Series	Littelfuse / JLLN060.T	Class T	AC 300 V, 60 A	60 A	10 kA

- (7) Suitable for circuit with maximum symmetrical short circuit current 5000 Arms.
- (8) The level of motor overload protection is the percentage of full-load current. (120 % of full-load current)
- (9) The drive module provides motor over-temperature protection, which can receive PTC signals.
- (10) Use copper conductors of rated temperature 75 °C.

# Safety Precautions

- Carefully read through this manual before installation, transportation, maintenance and examination. Ensure the product is correctly used in the manner that is defined as appropriate.
- Carefully read through electromagnetic (EM) information, safety information and related precautions before using the product.
- Safety precautions in this manual are classified into “DANGER,” “WARNING,” “CAUTION,” and “NOTICE.”

Signal Word	Description
	<b>Immediate danger!</b> Failure to observe the safety instructions will result in serious injury or death!
	<b>Possibly dangerous situation!</b> Failure to observe the safety instructions could result in serious injury or death!
	<b>Possibly dangerous situation!</b> Non-compliance with the safety instructions could result in moderate or minor injuries!
	<b>Possibly dangerous situation!</b> Non-compliance with the safety instructions could result in property damage or pollution!

Warning Signs			
	Electric shock!		High temperature!
	Fire!		Pinching injury!

## DANGER



- ◆ High electrical voltage and high working current! Danger to life or serious injury by electric shock!
- ◆ High electrical voltage by incorrect connection! Danger to life or serious injury by electric shock!
- ◆ Dangerous movements! Danger to life, serious injury or property damage by unintended motor movements!
- ◆ Health hazard for persons with heart pacemakers, metal implants and hearing aids in proximity to electric drive systems!
- ◆ Do not plug in the motor power cable or remove it from NPC when it is still power-on, or there is a risk of electric shock or damage to contact.
- ◆ Do not touch the live parts (contacts or bolts) within 15 minutes after disconnecting NPC from its power supply. For safety reason, we suggest measuring the voltage in the intermediate circuit and wait until it drops to 50 V<sub>DC</sub>.
- ◆ Disconnect electrical power to the components of the electric drive and control system with the master switch and secure them from reconnection for:
  - Maintenance and repair work
  - Cleaning of equipment
  - Long-term deactivation of equipment
- ◆ Prevent the operation of high-frequency, remote control, and radio equipment near components of the electric drive and control system and their supply leads. If the use of these devices cannot be avoided, check the machine or installation, at initial commissioning of the electric drive and control system, for possible malfunctions when operating the above-mentioned equipment in its possible positions of normal use. It might be necessary to perform a special electromagnetic compatibility (EMC) test.

## DANGER



### **Danger to life, risk of injury caused by electric shock due to high housing voltage!**

- ◆ Before switching on and before commissioning of the components, connect NPC with the protective earthing (PE) conductor at the grounding points.
- ◆ Safe operation is only guaranteed when the PE conductor is connected.
- ◆ The cross-section for the protective earthing connection must be selected in accordance with the applicable standards (e.g., IEC 60204-1, IEC 61800-5-1).
- ◆ The PE conductor from NPC must be connected to the supply network in a fixed manner.
- ◆ Ensure the protective earthing connection from the entire NPC and control system is connected with low impedance.
- ◆ Connect the bare metal back panel of NPC in an electrically conductive form with the mounting surface of the electric control box.
- ◆ Ensure the mounting surface is connected to the protective earthing system with low impedance.
- ◆ Even for brief measurements or tests, operation is only allowed if the PE conductor has been firmly connected to the grounding points.

## DANGER

### Lethal electric shock due to live parts of NPC with a contact voltage over 50 V!

In case of an interruption of the PE conductor, high leakage current can lead to dangerous voltage on conductive/touchable parts of the machine.

- ◆ Ensure NPC is grounded according to the standards.
- ◆ NPC may only be switched on and operated with a safely connected protective earthing system.
- ◆ Depending on the application, leakage current > 10 mA DC or > 3.5 mA AC may occur during operation of NPC and control system. In this case, observe the necessary measures for the PE conductor connection of the applicable standards (e.g., IEC 60204-1, IEC 61800-5-1).
- ◆ When the PE conductor is damaged or disconnected, the leakage current may be greater than 10 mA DC or 3.5 mA AC.



Possible hazard:

If users accidentally touch this product, electric shock may occur and cause serious injury or death.

Protective measures:

According to the requirements of IEC 61800-5-1 standard, one or more of the following precautions should be applied.

- Fixed connection
  - Connect PE conductor with cross-section  $\geq 10 \text{ mm}^2$  Cu or with cross-section  $\geq 16 \text{ mm}^2$  Al.
- Connection using industrial connectors according to IEC 60309
  - Use PE conductor with cross-section  $\geq 2.5 \text{ mm}^2$  as part of a multi-conductor power cable.
  - Provide adequate strain relief.

## CAUTION

### Protection against dangerous movements!



Dangerous movements can be caused by faulty control of connected motors. Some common examples are:

- ◆ Improper or wrong wiring / cable connection
- ◆ Operator errors
- ◆ Wrong input of parameters before commissioning
- ◆ Malfunction of sensors and encoders
- ◆ Defective components
- ◆ Software or firmware errors
- ◆ Wrong absolute position feedback

These errors can occur immediately after the equipment is switched on or even after an unspecified time of trouble-free operation.

■ Operation

 **DANGER**

 	<ul style="list-style-type: none"><li>◆ Do not touch the terminals or internal parts of the product when power on, or it may cause electric shock.</li><li>◆ Do not touch the terminals or internal parts of the product within fifteen minutes after power off, or the residual voltage may cause electric shock.</li><li>◆ Do not modify wiring when power on, or it may cause electric shock.</li><li>◆ Do not damage, apply excessive force to, place heavy object on the cables or put the cables between two objects. Otherwise, it may cause electric shock or fire.</li></ul>
--	---

 **WARNING**

- ◆ A risk assessment must be conducted to the machine or system for product installation with its specific conditions.  
According to the requirements of the risk assessment, users must be equipped with monitoring functions and higher-level measures during installation for personal safety. The safety regulations applicable to the machine or system must be included. Unintended machine movements or other malfunctions are possible if safety devices are disabled, bypassed or not activated.
- ◆ To avoid accident, injury or property damage, ensure the precautions are followed when operating:
  - Be away from the machine's range of motion and moving machine parts. Prevent personnel from accidentally entering the machine's range of motion by taking the measure such as:
    - Safety fences
    - Safety guards
    - Protective coverings
    - Light barriers
  - Ensure the safety fences and protective coverings are strong enough to resist maximum possible kinetic energy.

 **NOTICE**

- ◆ Observe the ambient and operating conditions specified in this manual.
- ◆ Do not use the product in location which is subject to humidity, corrosive materials, flammable gas or flammable materials.

■ Storage

 **NOTICE**



- ◆ Do not store the product in location which is subject to water, water drop, harmful gas, harmful liquid or direct sunlight.

■ Transportation

 **NOTICE**

- ◆ Carefully move the product to avoid damage.
- ◆ Do not apply excessive force to the product.
- ◆ Do not stack the products to avoid collapse.

■ Installation site

 <b>NOTICE</b>	
	<ul style="list-style-type: none"><li>◆ Do not install the product in location with high ambient temperature or high humidity or location which is subject to dust, iron powder or cutting powder.</li><li>◆ Install the product in location with ambient temperature stated in this manual. Use cooling fan if the ambient temperature is too high.</li><li>◆ Do not install the product in location which is subject to direct sunlight.</li><li>◆ The product is not drip-proof or waterproof, so do not install or operate the product outdoor or in location which is subject to water or liquid.</li><li>◆ Install the product in location with less vibration.</li><li>◆ Motor generates heat while running for a period of time. Use cooling fan or disable the motor when it is not in use, so the ambient temperature will not exceed its specification.</li></ul>

■ Installation



 <b>DANGER</b>	
	<ul style="list-style-type: none"><li>◆ Prevent any foreign object from entering the product, or it may cause fire.</li><li>◆ Install the product in the specified orientation, or it may cause fire.</li><li>◆ Install the product on noncombustible object such as metal to avoid fire.</li></ul>

 <b>WARNING</b>	
	<ul style="list-style-type: none"><li>◆ Do not place heavy object on the product, or it may cause injury.</li><li>◆ Avoid strong shock to the product, or it may cause malfunction or injury.</li></ul>

 <b>NOTICE</b>	
<ul style="list-style-type: none"><li>◆ While installing the product, take its weight into consideration. Improper installation may cause damage to the product.</li><li>◆ Install the product inside a supplementary enclosure or in a restricted-access area which provides appropriate protection against spread of fire and electric shock.</li></ul>	

■ Wiring

 <b>DANGER</b>	
	<ul style="list-style-type: none"><li>◆ Ensure wiring is correctly performed. Otherwise, it may lead to product malfunction or burn-out. There could be a risk of injury or fire.</li></ul>

 <b>CAUTION</b>	
	<ul style="list-style-type: none"><li>◆ The peripheral devices, including controller, must share the same power supply system with NPC. Otherwise, the voltage difference between the devices and NPC could result in burn-out.</li></ul>

■ Operation and transportation

 **DANGER**



- ◆ Use power supply specified in product specification, or it may cause injury or fire.
- ◆ The product may suddenly start to operate after power supply recovers. Please do not get too close to the product.

 **WARNING**

- ◆ Set external wiring for emergency stop to stop the motor at any time.
- ◆ Mount emergency stopping switches in the immediate reach of the operator. Before commissioning, verify that the emergency stopping equipment works. Do not operate the machine if the emergency stopping switch is not working.
- ◆ Prevent unintended start-up. Isolate the NPC power connection by means of OFF switches/OFF buttons or use a safety lockout.

■ Maintenance

 **NOTICE**

- ◆ Do not disassemble or modify the product.
- ◆ If the product malfunctions, do not repair the product by themselves. Please contact HIWIN MIKROSYSTEM for repair.

## Chapter Overview

Chapter	Title	Contents
1	NPC selection	This chapter introduces nameplate and model explanation of NPC.
2	NPC specification	This chapter provides specification, dimensions, and installation instructions of NPC.
3	Electrical planning	This chapter provides wiring precautions and connector introduction.
4	Appendix	This chapter provides the replacement standard and the required accessories for NPC setup.

# Table of Contents

1. NPC selection .....	1-1
1.1 Model explanation of NPC .....	1-2
1.1.1 Nameplate .....	1-2
1.1.2 Model explanation .....	1-3
2. NPC specification .....	2-1
2.1 Dimensions.....	2-2
2.2 Installation .....	2-5
2.3 Specification .....	2-7
2.3.1 Power module.....	2-7
2.3.2 Drive module .....	2-8
2.3.3 Control module .....	2-9
2.3.4 Dual-axis pulse module .....	2-10
2.4 Environment .....	2-11
3. Electrical planning .....	3-1
3.1 Wiring precautions .....	3-2
3.1.1 General precautions .....	3-2
3.1.2 Countermeasures against interference .....	3-5
3.1.3 Grounding.....	3-6
3.2 Wiring diagrams .....	3-7
3.2.1 Connections to peripheral devices .....	3-7
3.2.2 Power terminals and connectors .....	3-9
3.3 Wiring for power supply (CN1, CN6).....	3-10
3.3.1 Terminal symbols and terminal names.....	3-10
3.3.2 Wiring for regenerative resistor .....	3-12
3.4 Wiring for servo motor .....	3-14
3.4.1 Terminal symbols and terminal names.....	3-14
3.4.2 Motor power connector (CN5).....	3-15
3.4.3 Encoder connector (CN3).....	3-15
3.4.4 Wiring for brake (CN4, BK).....	3-17
3.4.5 Motor thermal sensor connector (CN4, OT).....	3-18
3.5 I/O signals (CN11, CN12) .....	3-19
3.5.1 I/O signal connector.....	3-19
3.5.2 Wirings for inputs and outputs.....	3-23
3.6 STO connector (CN8) .....	3-26
3.6.1 Pin definition of STO connector.....	3-26
3.6.2 Wiring for STO safety function .....	3-27
3.7 Communication connectors.....	3-28
3.7.1 Connector for PC communication (CN7).....	3-28

3.7.2 Connector for Fieldbus communication (CN10) .....	3-28
3.7.3 Connector for API library communication (CN9) .....	3-29
4. Appendix .....	4-1
4.1 Maintenance .....	4-2
4.1.1 Regular inspection .....	4-2
4.1.2 Replacement standard .....	4-2
4.2 Accessories .....	4-3
4.2.1 Accessory kit .....	4-3
4.2.2 Selection of system peripherals .....	4-4

# 1. NPC selection

---

1. NPC selection .....	1-1
1.1 Model explanation of NPC .....	1-2
1.1.1 Nameplate .....	1-2
1.1.2 Model explanation .....	1-3

# 1.1 Model explanation of NPC

## 1.1.1 Nameplate



Figure 1.1.1.1 NPC-X-A□-D□ series



Figure 1.1.1.2 NPC-X-A□-A□ series

### 1.1.2 Model explanation

The model explanation of NPC is provided in the table below.

Table 1.1.2.1

Coding Item	Code	Example	Coding Option
Series	1~3	NPC	Nano Position Controller
Number of Driven Axes	4	X	X = 10 axes
Control Module	5~6	AP	AP = Full-function + Position trigger AN = Full-function
Power Module	7~8	D0	A0 = AC power: single-phase 100~240 Vrms; three-phase 200~240 Vrms D0 = DC power: 24~100 Vdc
1 <sup>st</sup> Slot	9~10	10	Supports up to 8 slots. Unused slot codes must be omitted, and end codes should be shifted forward.  AC drive module: 06 = 6.3 Arms  DC drive module: 10 = 10.6 Arms  Function module: P0 = Dual-axis pulse module
2 <sup>nd</sup> Slot	11~12	10	
3 <sup>rd</sup> Slot	13~14	10	
4 <sup>th</sup> Slot	15~16	10	
5 <sup>th</sup> Slot	17~18	10	
6 <sup>th</sup> Slot	19~20	10	
7 <sup>th</sup> Slot	21~22	10	
8 <sup>th</sup> Slot	23~24	P0	
Reserved	25~28	0000	Reserved

Depending on the application, confirm whether the input power is DC or AC. The maximum number of control axes is 10, and the module supports up to 8 slots. It can be expanded to a total of 10 motion control axes via external Fieldbus connection.

Example:

- Using DC 48 V power supply, requiring position trigger function for camera inspection, driving 3-axis linear motor, 1-axis direct drive motor, 2-axis voice coil motor, and 2-axis stepper motor, NPC-X-AP-D0-101010101010P0-0000 can be selected.
- Using AC 220 V power supply, no need to output position trigger signals to any device, driving 5-axis linear motor, 1-axis direct drive motor, and 2-axis AC servo motor, NPC-X-AN-A0-0606060606060606-0000 can be selected.

(This page is intentionally left blank.)

## 2. NPC specification

---

2. NPC specification .....	2-1
2.1 Dimensions.....	2-2
2.2 Installation .....	2-5
2.3 Specification .....	2-7
2.3.1 Power module.....	2-7
2.3.2 Drive module .....	2-8
2.3.3 Control module .....	2-9
2.3.4 Dual-axis pulse module .....	2-10
2.4 Environment .....	2-11

## 2.1 Dimensions

The dimensions and locations of installation holes of NPC are provided below. The dimensions are shown in millimeters (mm). The diameter of installation hole is 5.2 mm.

■ 4-axis

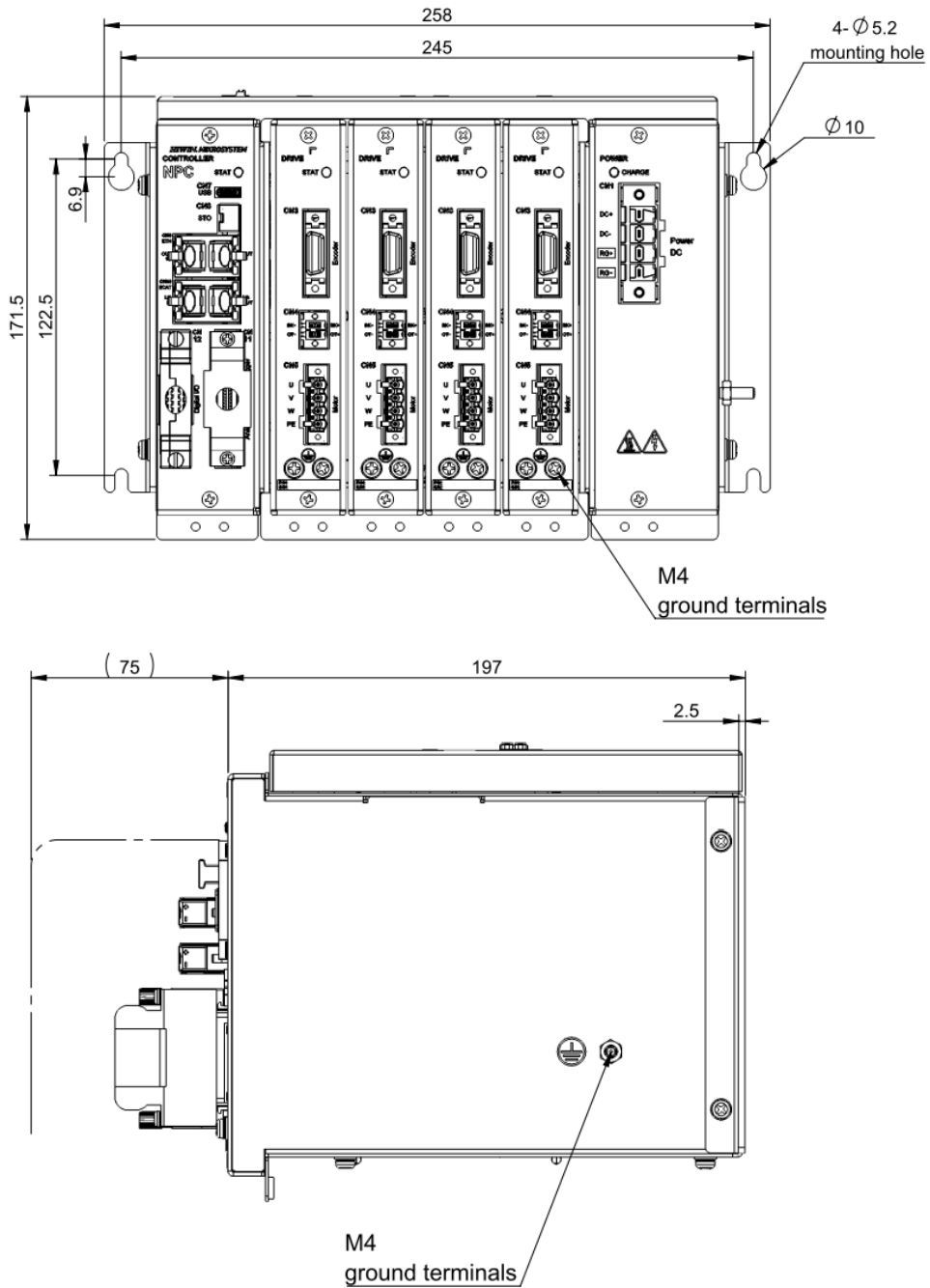

NPC-X-A□-D□ series: Weight 4.08 kg  
 NPC-X-A□-A□ series: Weight 4.32 kg

Figure 2.1.1 Dimensions of 4-axis

■ 6-axis

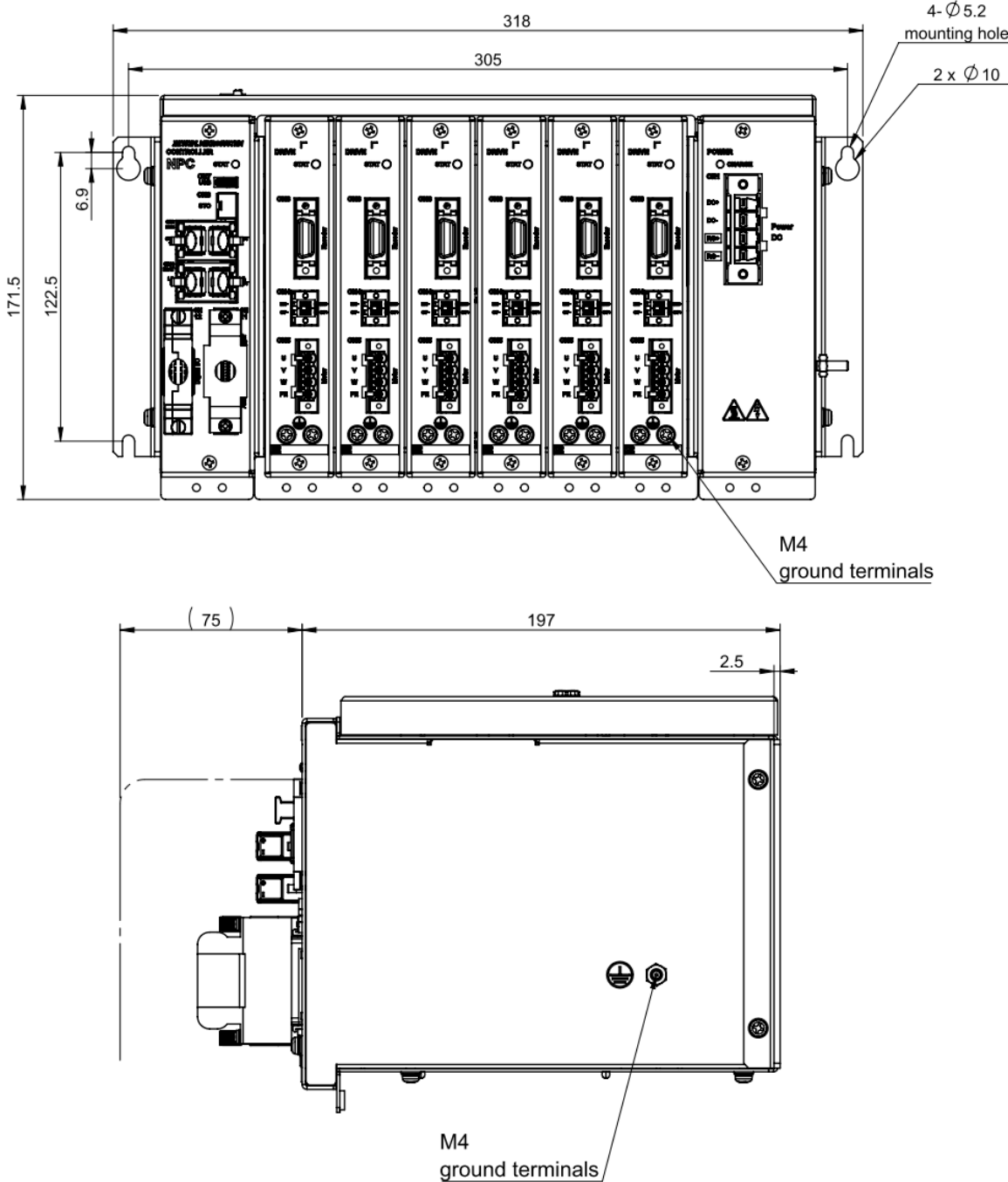

NPC-X-A□-D□ series: Weight 5.07 kg  
NPC-X-A□-A□ series: Weight 5.31 kg

Figure 2.1.2 Dimensions of 6-axis

■ 8-axis

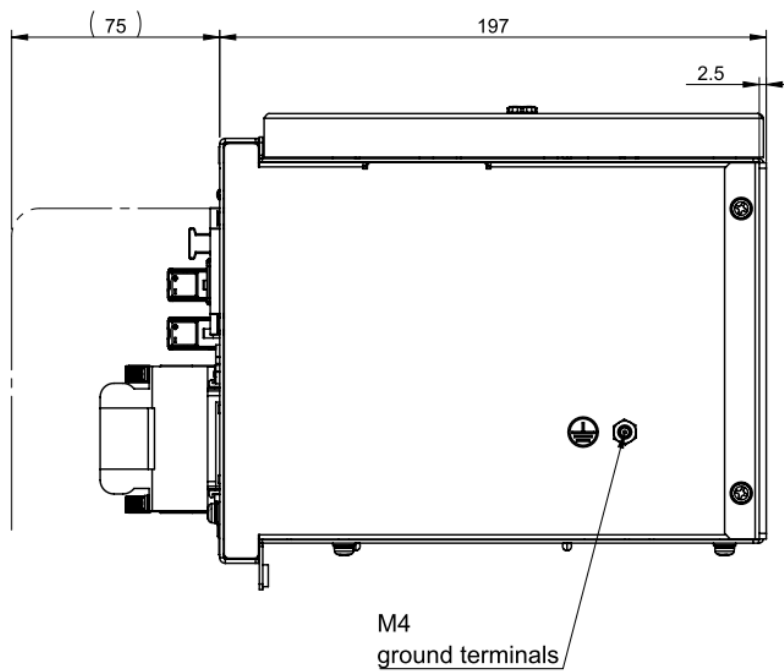
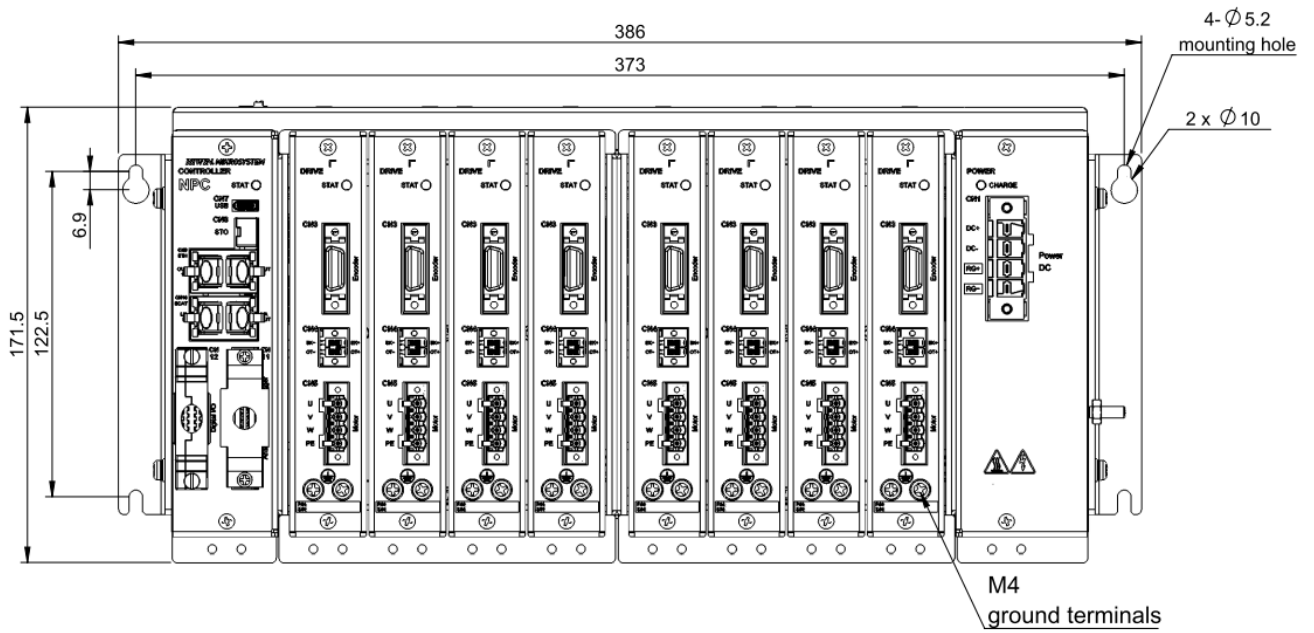

NPC-X-A□-D□ series: Weight 6.24 kg  
 NPC-X-A□-A□ series: Weight 6.48 kg

Figure 2.1.3 Dimensions of 8-axis

## 2.2 Installation

If NPC is installed in a control box, ensure it is mounted with conductive screws based on the suggested length, size and torque. The insulating materials on the contact surface of the control box, such as paint, must be removed for grounding NPC through the control box. When the input power of NPC is AC 220 V, the grounding resistance must be lower than 50 Ω; when the input power of NPC is AC 110 V or DC, the grounding resistance must be lower than 100 Ω. The suction hole and vent hole of NPC must not be obstructed. Install NPC according to the specified orientation; otherwise, it may malfunction.

Note:

The value of the grounding resistance is from Class III electrical standards.

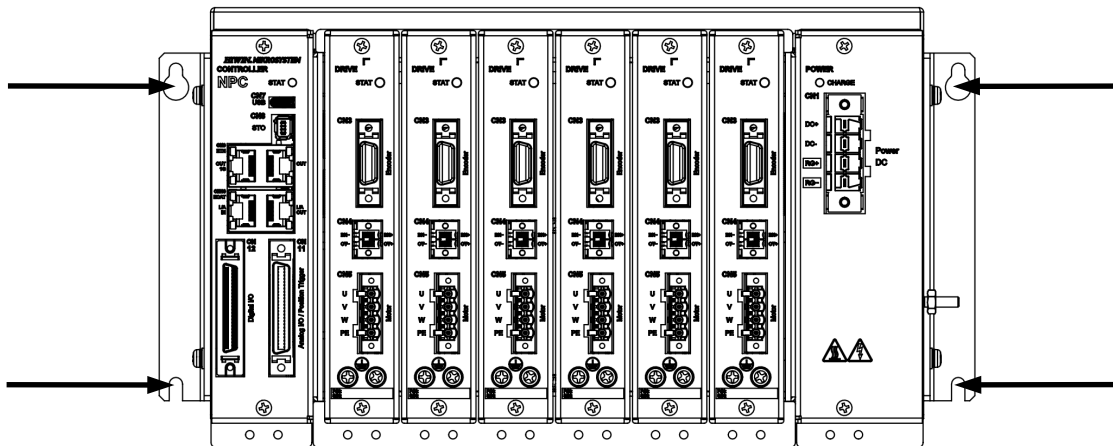

Figure 2.2.1 Tighten the parts with screw driver

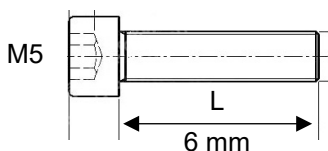

Figure 2.2.2

Table 2.2.1

Screw Specification	Lock Torque (Nm)
M5, 6 mm	1.5

For well cooling and circulation effect, there must be enough clearance between NPC and the adjacent objects or baffle plates. Install a fan in the control box to facilitate heat dissipation.

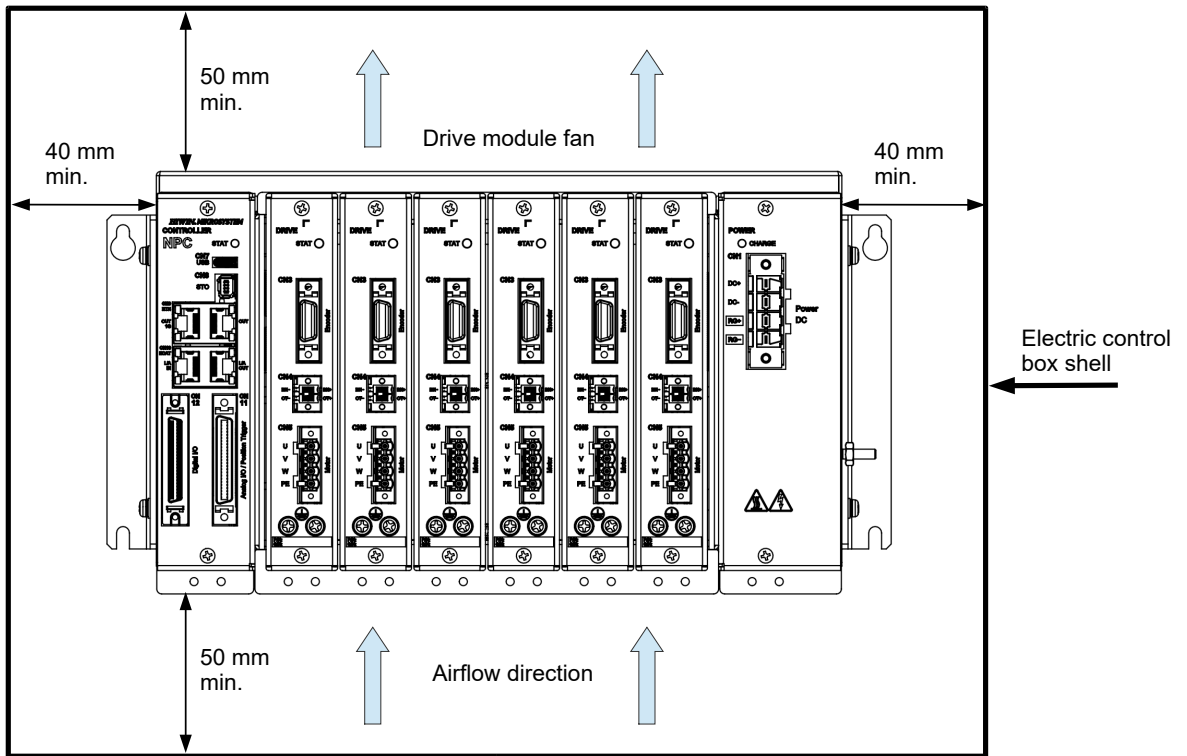

Figure 2.2.3 Installing NPC

## 2.3 Specification

### 2.3.1 Power module

Table 2.3.1.1 Power module specification

NPC Model		NPC-X-A□-D□ Series	NPC-X-A□-A□ Series	
STAT LED Indicator		<ul style="list-style-type: none"> <li>● Green: The main power is supplied.</li> <li>● No light: The main power is not supplied.</li> </ul>		
Input Power	DC Power	Rated Voltage	DC 24 ~ 100 V	-
		Rated Current (A)	41	-
		Power (W)	4000	-
	Single-phase Main Power	Rated Voltage (Line to Line)	-	AC 100 ~ 120 Vrms, 50 ~ 60 Hz
		Rated Current (Arms)	-	34.5
		Power (W)	-	2000
		Rated Voltage (Line to Line)	-	AC 200 ~ 240 Vrms, 50 ~ 60 Hz
		Rated Current (Arms)	-	35.4
		Power (W)	-	4000
		Three-phase Main Power	Rated Voltage (Line to Line)	-
	Rated Current (Arms)		-	38.6
	Power (W)		-	8000
	Inrush Current of Main Power (Apk)		-	25.1
Regenerative Energy Protection	Regenerative Resistor	Without built-in regenerative resistor. Connect to external regenerative resistor if needed.		
	Allowable Resistance of External Regenerative Resistor	Min. 6.3 Ohm	Min. 13 Ohm	
	DC Link Capacitance	5100 uF @4-Axis 5400 uF @6-Axis 5700 uF @8-Axis	3520 uF @4-Axis 3880 uF @6-Axis 4240 uF @8-Axis	
	Protection of Regenerative Resistor Enabled	+HV > 102 Vdc	+HV > 400 Vdc	
	Protection of Regenerative Resistor Disabled	+HV < 100 Vdc	+HV < 390 Vdc	
	Oversvoltage Protection	125 Vdc	420 Vdc	
Cooling Method		Natural cooling	Fan cooling	
Voltage Category Level for each Connector		<ul style="list-style-type: none"> <li>● DVC C: CN1 (NPC-X-A□-A□ series)</li> <li>● DVC B: CN1 (NPC-X-A□-D□ series)</li> </ul>		

**2.3.2 Drive module**

Table 2.3.2.1 Drive module specification

NPC Model			NPC-X-A□-D□ Series	NPC-X-A□-A□ Series
STAT LED Indicator			<ul style="list-style-type: none"> <li>● Red: Error</li> <li>● Blinking green: Ready</li> <li>● Green: Enabled</li> </ul>	
Output Power	Phase Voltage		3 PH / AC 70 Vrms max.	3 PH / AC 240 Vrms max.
	Maximum Rated Power (W)		1000	1000
	Peak Current (Arms)		21.21	18
	Rated Current (Arms)		10.6	6.3
Supported Motor Type			<ul style="list-style-type: none"> <li>● Linear motor</li> <li>● Direct drive motor</li> <li>● AC servo motor</li> <li>● Voice coil motor</li> </ul>	
Dynamic Brake			<ul style="list-style-type: none"> <li>● Built-in dynamic brake function, reducing the slip distance of motor after power off</li> <li>● No built-in dynamic brake resistor</li> <li>● Delay time of relay: 15 ms</li> </ul>	
Encoder	Power Supply		+5.2 Vdc ±5%, 2000 mA	
	Signal Format	Serial Signal	TAMAGAWA	<ul style="list-style-type: none"> <li>● Resolution: 23 bit</li> <li>● Bandwidth: 5 MHz</li> </ul>
			BiSS-C	<ul style="list-style-type: none"> <li>● Maximum data length: 64 bit</li> <li>● Bandwidth: 5 MHz</li> </ul>
			EnDat	<ul style="list-style-type: none"> <li>● Maximum data length: 64 bit</li> <li>● Bandwidth: 4 MHz</li> </ul>
	Incremental Signal	Digital	<ul style="list-style-type: none"> <li>● AqB and Z-phase signals (Digital differential TTL signal)</li> <li>● The maximum input bandwidth of each phase is 25 MHz.</li> <li>● Quadruple frequency: 100 Mcounts/s</li> </ul>	
		Analog	<ul style="list-style-type: none"> <li>● SIN/COS signal (Differential signal)</li> <li>● The maximum input bandwidth is 1 MHz.</li> <li>● Maximum multiplier factor: 65536 times</li> <li>● Input signal is 0.3~1.2 Vpp.</li> </ul>	
	Safety Function		<ul style="list-style-type: none"> <li>● Encoder power malfunction detection</li> <li>● Encoder alarm protection (Digital differential signal)</li> <li>● Main power overvoltage and undervoltage protection</li> </ul>	
Maximum Position Counting Range		64 bit		
Gantry Control		Master-Slave Configuration	Axis 1 and axis 2 form a group, axis 3 and axis 4 form another group, and so on.	
		Bandwidth	8.33 MHz	
Cooling Method			Fan cooling	Fan cooling
Voltage Category Level for each Connector			<ul style="list-style-type: none"> <li>● DVC C: CN5 (NPC-X-A□-A□ series)</li> <li>● DVC B: CN5 (NPC-X-A□-D□ series)</li> <li>● DVC A: CN3, CN4</li> </ul>	

### 2.3.3 Control module

Table 2.3.3.1 Control module specification

Category		Specification
STAT LED Indicator		<ul style="list-style-type: none"> <li>● Blinking red: Error</li> <li>● Blinking green: Boot Mode</li> <li>● Green: Normal Mode</li> </ul>
Host Interface	USB Port	<ul style="list-style-type: none"> <li>● Channel: 1</li> <li>● Format: USB2.0 Type-C</li> <li>● Transmission rate: 12 Mbps</li> </ul>
	Ethernet Port	<ul style="list-style-type: none"> <li>● Channel: 1</li> <li>● Format: Ethernet Protocol</li> <li>● Transmission rate: 100 / 1000 Mbps</li> </ul>
EtherCAT Interface		<ul style="list-style-type: none"> <li>● Channel: 2</li> <li>● Format: EtherCAT Protocol</li> <li>● Transmission rate: 100 Mbps</li> </ul>
Ethernet Expansion Interface		<ul style="list-style-type: none"> <li>● Channel: 1</li> <li>● Format: Ethernet Protocol</li> <li>● Transmission rate: 100 / 1000 Mbps</li> <li>● When using mega-ulink communication, transfer rate is limited to 100 Mbps.</li> </ul>
General-purpose I/O	Digital Input	<ul style="list-style-type: none"> <li>● The functions of general-purpose inputs (Optical couplers) can be defined by users.</li> <li>● Channel: 24</li> <li>● Format: Single-ended Sink or Source</li> <li>● Operating range: DC 5 ~ 24 V</li> <li>● Maximum input current: 5 mA (Each input pin)</li> </ul>
	Digital Output	<ul style="list-style-type: none"> <li>● The functions of general-purpose outputs (Optical couplers) can be defined by users.</li> <li>● Channel: 8</li> <li>● Format: Single-ended Sink</li> <li>● Operating range: DC 0 ~ 24 V</li> <li>● Maximum output current: 100 mA (Each output pin)</li> </ul>
High-speed Inputs and Outputs		<ul style="list-style-type: none"> <li>● The functions of high-speed inputs and outputs can be defined by users.</li> <li>● Channel: 4</li> <li>● Format: Differential RS485</li> <li>● Operating range: <math>\pm 3</math> V <math>\pm 1\%</math></li> <li>● Terminal impedance: <math>120 \Omega \pm 10\%</math></li> </ul>
Analog Input		<ul style="list-style-type: none"> <li>● Channel: 8</li> <li>● Format: Differential</li> <li>● Operating range: <math>\pm 10</math> V <math>\pm 1\%</math></li> <li>● Maximum input bandwidth: 5 kHz</li> <li>● Resolution: 16 bit</li> </ul>
Analog Output		<ul style="list-style-type: none"> <li>● Channel: 6</li> <li>● Format: Differential</li> <li>● Operating range: <math>\pm 10</math> V <math>\pm 1\%</math></li> <li>● Maximum output current: <math>\pm 10</math> mA</li> <li>● Resolution: 16 bit</li> </ul>
Position Trigger Output		<ul style="list-style-type: none"> <li>● Channel: 10</li> <li>● Format: Differential RS422</li> <li>● Operating range: <math>\pm 10</math> V <math>\pm 1\%</math></li> <li>● Minimum pulse width: 20 ns</li> <li>● Maximum output bandwidth: 20 MHz</li> </ul>
Safety Function		STO 1oo2
Control Power Input		<ul style="list-style-type: none"> <li>● Rated voltage: DC 24 V <math>\pm 10\%</math></li> <li>● Rated current: 3 A</li> </ul>
Voltage Category Level for each Connector		DVC A: CN6, CN7, CN8, CN9, CN10, CN11, CN12

### 2.3.4 Dual-axis pulse module

Table 2.3.4.1 Dual-axis pulse module specification

Category			Specification	
STAT LED Indicator			<ul style="list-style-type: none"> <li>● Red: Error</li> <li>● Blinking green: Ready</li> <li>● Green: Enabled</li> </ul>	
Pulse Output	Maximum Number of Supported Axes		2 axes	
	Signal Format		<ul style="list-style-type: none"> <li>● Pulse/Direction (Differential signal)</li> <li>● CW/CCW (Differential signal)</li> <li>● AqB (Differential signal)</li> </ul>	
	Signal Bandwidth		8 MHz	
General-purpose I/O		Digital Input	<ul style="list-style-type: none"> <li>● The functions of general-purpose inputs (Optical couplers) can be defined by users.</li> <li>● Channel: 8</li> <li>● Format: Single-ended Sink or Source</li> <li>● Operating range: DC 5 ~ 24 V</li> <li>● Maximum input current: 5 mA (Each input pin)</li> </ul>	
		Digital Output	<ul style="list-style-type: none"> <li>● The functions of general-purpose outputs (Optical couplers) can be defined by users.</li> <li>● Channel: 8</li> <li>● Format: Single-ended Sink</li> <li>● Operating range: DC 0 ~ 24 V</li> <li>● Maximum output current: 100 mA (Each output pin)</li> </ul>	
Encoder	Power Supply		+5.2 Vdc ±5%, 2000 mA	
	Signal Format	Serial Signal	TAMAGAWA	<ul style="list-style-type: none"> <li>● Resolution: 23 bit</li> <li>● Bandwidth: 5 MHz</li> </ul>
			BiSS-C	<ul style="list-style-type: none"> <li>● Maximum data length: 64 bit</li> <li>● Bandwidth: 5 MHz</li> </ul>
		EnDat	<ul style="list-style-type: none"> <li>● Maximum data length: 64 bit</li> <li>● Bandwidth: 4 MHz</li> </ul>	
	Incremental Signal	Digital	<ul style="list-style-type: none"> <li>● AqB and Z-phase signals (Digital differential TTL signal)</li> <li>● The maximum input bandwidth of each phase is 25 MHz.</li> <li>● Quadruple frequency: 100 Mcounts/s</li> </ul>	
Encoder Output	Emulated Encoder Output		Z Phase	<ul style="list-style-type: none"> <li>● Supports serial encoders and digital encoders (AqB)</li> <li>● Digital differential signal output</li> </ul>
			A/B Phase	<ul style="list-style-type: none"> <li>● Supports serial encoders and digital encoders (AqB)</li> <li>● Digital differential signal output, maximum output bandwidth 18 Mcounts/s</li> </ul>
	Buffered Encoder Output		Z Phase	<ul style="list-style-type: none"> <li>● Only supports digital encoders (AqB)</li> <li>● Differential signal output</li> </ul>
			A/B Phase	<ul style="list-style-type: none"> <li>● Only supports digital encoders (AqB)</li> <li>● Differential signal output, maximum output bandwidth 50 Mcounts/s</li> </ul>
Voltage Category Level for each Connector			DVC A: CN14, CN15	

## 2.4 Environment

Table 2.4.1

Category	Specification
Altitude	Approved for use at 2,000 M or lower height above sea level
Operating Temperature	0°C ~ 40°C
Storage Temperature	-20°C ~ 65°C
Humidity	20 ~ 85% RH (Non-condensing)
Vibration	10 Hz ~ 57 Hz: 0.075 mm amplitude 58 Hz ~ 150 Hz: 1G
Pollution Degree	2
IP Rating	IP20
Power System	TT / TN system

(This page is intentionally left blank.)

## 3. Electrical planning

3. Electrical planning .....	3-1
3.1 Wiring precautions .....	3-2
3.1.1 General precautions .....	3-2
3.1.2 Countermeasures against interference .....	3-5
3.1.3 Grounding .....	3-6
3.2 Wiring diagrams .....	3-7
3.2.1 Connections to peripheral devices .....	3-7
3.2.2 Power terminals and connectors .....	3-9
3.3 Wiring for power supply (CN1, CN6).....	3-10
3.3.1 Terminal symbols and terminal names.....	3-10
3.3.2 Wiring for regenerative resistor .....	3-12
3.4 Wiring for servo motor .....	3-14
3.4.1 Terminal symbols and terminal names.....	3-14
3.4.2 Motor power connector (CN5).....	3-15
3.4.3 Encoder connector (CN3).....	3-15
3.4.4 Wiring for brake (CN4, BK).....	3-17
3.4.5 Motor thermal sensor connector (CN4, OT).....	3-18
3.5 I/O signals (CN11, CN12) .....	3-19
3.5.1 I/O signal connector.....	3-19
3.5.2 Wirings for inputs and outputs .....	3-23
3.6 STO connector (CN8) .....	3-26
3.6.1 Pin definition of STO connector.....	3-26
3.6.2 Wiring for STO safety function .....	3-27
3.7 Communication connectors.....	3-28
3.7.1 Connector for PC communication (CN7).....	3-28
3.7.2 Connector for Fieldbus communication (CN10) .....	3-28
3.7.3 Connector for API library communication (CN9).....	3-29

## 3.1 Wiring precautions

### 3.1.1 General precautions

#### **DANGER**



- ◆ Do not modify wiring when power on.  
Do not modify wiring when power on, or it may cause electric shock or injury.

#### **DANGER**



##### **Danger to life, risk of injury caused by electric shock due to high housing voltage!**

- ◆ Before switching on and before commissioning of the components, connect NPC with the protective earthing (PE) conductor at the grounding points.
- ◆ Safe operation is only guaranteed when the PE conductor is connected.
- ◆ The cross-section for the protective earthing connection must be selected in accordance with the applicable standards (e.g., IEC 60204-1, IEC 61800-5-1).
- ◆ The PE conductor from NPC must be connected to the supply network in a fixed manner.
- ◆ Ensure the protective earthing connection from the entire NPC and control system is connected with low impedance.
- ◆ Connect the bare metal back panel of NPC in an electrically conductive form with the mounting surface of the electric control box.
- ◆ Ensure the mounting surface is connected to the protective earthing system with low impedance.
- ◆ Even for brief measurements or tests, operation is only allowed if the PE conductor has been firmly connected to the grounding points.

#### **DANGER**



##### **Lethal electric shock due to live parts of NPC with a contact voltage over 50 V!**

In case of an interruption of the PE conductor, high leakage current can lead to dangerous voltage on conductive/touchable parts of the machine.

- ◆ Ensure NPC is grounded according to the standards.
- ◆ NPC may only be switched on and operated with a safely connected protective earthing system.
- ◆ Depending on the application, leakage current > 10 mA DC or > 3.5 mA AC may occur during operation of NPC and control system. In this case, observe the necessary measures for the PE conductor connection of the applicable standards (e.g., IEC 60204-1, IEC 61800-5-1).

 **DANGER**



- ◆ When the PE conductor is damaged or disconnected, the leakage current may be greater than 10 mA DC or 3.5 mA AC.  
Possible hazard:  
If users accidentally touch this product, electric shock may occur and cause serious injury or death.  
Protective measures:  
According to the requirements of IEC 61800-5-1 standard, one or more of the following precautions should be applied.
  - Fixed connection  
→ Connect PE conductor with cross-section  $\geq 10 \text{ mm}^2$  Cu or with cross-section  $\geq 16 \text{ mm}^2$  Al.
  - Connection using industrial connectors according to IEC 60309  
→ Use PE conductor with cross-section  $\geq 2.5 \text{ mm}^2$  as part of a multi-conductor power cable.  
→ Provide adequate strain relief.
- ◆ Earth leakage circuit breaker must be applied.  
NPC has no protective circuit for grounding fault. To have a safer system, it is suggested to install earth leakage circuit breaker or earth leakage circuit breaker with molded-case circuit breaker to prevent overload or short circuit.

 **WARNING**



- ◆ Wiring or examination must be performed by professional technician.  
If this is not followed, it may cause electric shock or product malfunction.
- ◆ Ensure wiring is correctly performed and the specified power is provided.  
Short circuit may occur in output circuits due to incorrect wiring or voltage. If short circuit is caused by the above reasons, brake will not be enabled. And this may cause machine damage, injury or death.
- ◆ Connect the main power to the terminals of NPC.
  - If DC main power is used, connect to terminals DC+ and DC- on NPC.
  - If AC main power is used, connect to terminals L1, L2, and L3 on NPC.
 If this is not followed, it may cause product malfunction or fire.

**⚠ CAUTION**

- ◆ Wiring and examination must be performed at least five minutes after power off and the indicator goes off. The residual voltage inside NPC could still be high after power off. Do not touch the power terminals when the indicator goes on. If this is not followed, it may cause electric shock.
- ◆ Wiring and trial operation must be performed in accordance with the precautions and procedures given in this manual. If brake circuit malfunctions due to incorrect wiring or voltage, this may cause product malfunction, machine damage, injury, or death.
- ◆ Wiring must be correctly performed. Connectors and pin definitions vary with different models. Before wiring, refer to the technical documents of the model. If this is not followed, it may cause product malfunction or false operation.
- ◆ Connect wires to the power terminals and motor terminals by following the given instructions. If this is not followed, the wires and terminal blocks could overheat due to poor connection. And this may cause fire.
- ◆ Use shielded twisted-pair cables or shielded multi-core twisted-pair cables for I/O signal cable and encoder cable.
- ◆ While wiring the terminals of NPC main circuit, please pay attention to the following.
  - (1) Turn on the power after wiring completes.
  - (2) While wiring a connector, remove the connector from NPC first.
  - (3) Insert one wire per one terminal socket.
  - (4) Ensure there is no short circuit among wires.
- ◆ Use circuit breaker or other safety device as protection for short circuit of external wiring. If this is not followed, it may cause fire or product malfunction.

**⚠ NOTICE**

- ◆ Use the cables specified by HIWIN MIKROSYSTEM while wiring.  
If cables which are not specified by HIWIN MIKROSYSTEM are used, perform wiring by using the wiring materials specified by HIWIN MIKROSYSTEM or equivalent products after checking the rated current of NPC and environment.
- ◆ Ensure the screws on cable connectors are tightened and NPC is securely installed inside the control box.  
If the screws are not tightened, the cable connectors could fall off during operation.
- ◆ Do not put high power cables (such as main circuit power cable) and low power cables (such as I/O signal cable and encoder cable) in the same cable tray or tie them together. If high power cable and low power cable are not put in separate cable trays, they should be at least 30 cm apart.  
If this is not followed, false operation may occur when low power cable is interfered.
- ◆ Encoder battery must be installed on encoder cable.
- ◆ While installing encoder battery, pay attention to its polarity.  
A broken battery may cause encoder malfunction.

**Important Reminders**

- Circuit breaker or fuse must be applied to protect the main circuit. If NPC is directly connected to a commercial power supply and is not insulated by transformer or other device, circuit breaker or fuse must be used to prevent the servo system from being affected by external system.
- Do not frequently turn on or turn off the power of NPC.
  - The internal components of NPC may be deteriorated if the power is frequently turned on or off.
  - The interval between power on and power off must be at least 15 minutes after operation starts.

For a safe and stable servo system, the following must be followed while wiring.

- (1) Use the cables specified by HIWIN MIKROSYSTEM. While designing and configuring a system, the cables must be as short as possible.
- (2) The conductors of signal cable are as thin as 0.2 mm<sup>2</sup> or 0.3 mm<sup>2</sup>. Do not bend or apply tension to the cable.

### 3.1.2 Countermeasures against interference

NPC has sophisticated microprocessors. If wiring or grounding is not correctly performed, NPC could be interfered by peripheral equipment. To avoid false operation caused by interference, follow the instructions below to configure NPC.

- (1) Do not put main circuit power cable, control signal cable and encoder cable in the same cable tray or tie them together. If they are not put in separate cable trays, they should be at least 30 cm apart while wiring.
- (2) NPC must not share the same power supply with electric welding machine or electric discharge machine. If there is high frequency generator near NPC, install noise filter at the input sides of main circuit power cable and control circuit power cable.
- (3) Grounding must be correctly performed. For information of grounding, please refer to section 3.1.3.
- (4) While using motor with large capacity, NPC could be interfered by noise from conduction or radiation. Use shielded motor power cable and its shield must be connected to the grounding of electric control panel.

Note:

For suggested filter, please refer to section 4.2.1.

### 3.1.3 Grounding

To prevent interference from causing false operation, perform grounding by following the instructions below.

- (1) Use the third type grounding or D type grounding (Different voltage has different grounding resistance value).
- (2) NPC cannot share the same power supply with electric welding machine or electric discharge machine. If there is high frequency generator near NPC, install noise filter at the input sides of main circuit power cable and control circuit power cable. For installation instructions of noise filter, please refer to section 3.1.2.
- (3) The ground wire must be as short as possible. Parallel and single-point grounding is suggested.
- (4) If servo motor is insulated from machine, ground the servo motor directly.
- (5) If there is high frequency generator (such as electric welding machine, electric discharge machine or frequency converter) in servo system, the high frequency generator must be grounded independently to avoid interference to other device.
- (6) When servo motor is grounded through a machine, switching noise current may flow out from NPC main circuit via the stray capacitance of the servo motor. To avoid the above situation, connect the frame or grounding terminal of the servo motor to the grounding terminal  $\oplus$  of NPC's drive module. Then ground the grounding terminal  $\oplus$  of NPC's drive module. The grounding terminal on the side of NPC's power module must also be tightened with nuts. When linear motor is used, both the forcer and stator must be grounded.
- (7) When control module's signal cable is interfered, connect its shield to its connector shell. Then perform grounding.

Reference torque value for grounding nut / screw lock:

Power Module Grounding			
Nut specification	Lock torque (Nm)	Wire size (AWG)	Terminal type
M4	1.2~1.5	8~14	R type

Drive Module Grounding			
Screw specification	Lock torque (Nm)	Wire size (AWG)	Terminal type
M4	1.2~1.5	8~14	R type

## 3.2 Wiring diagrams

### 3.2.1 Connections to peripheral devices

■ NPC-X-A□-D□ series

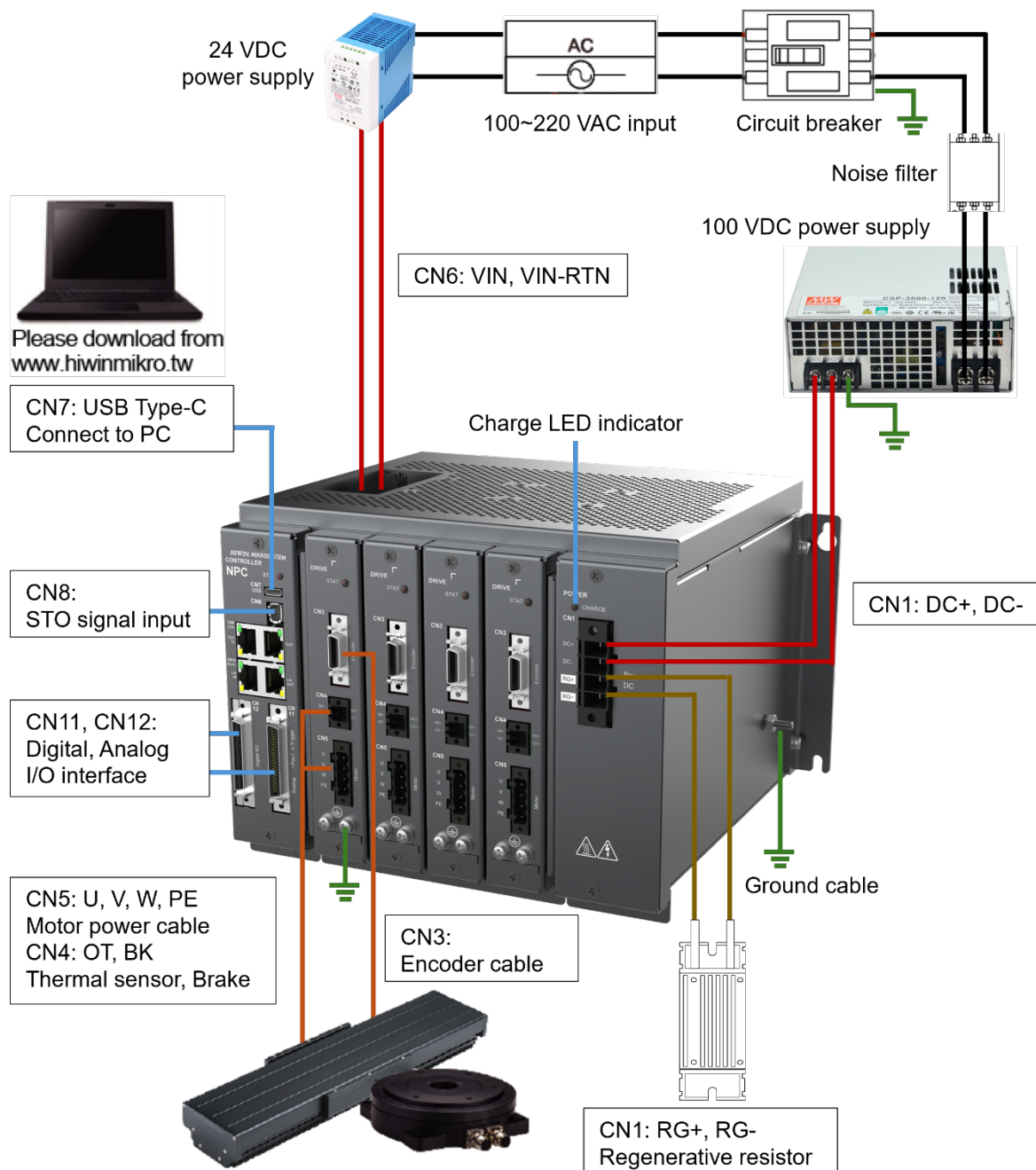

Figure 3.2.1.1 NPC-X-A□-D□ series

■ NPC-X-A□-A□ series

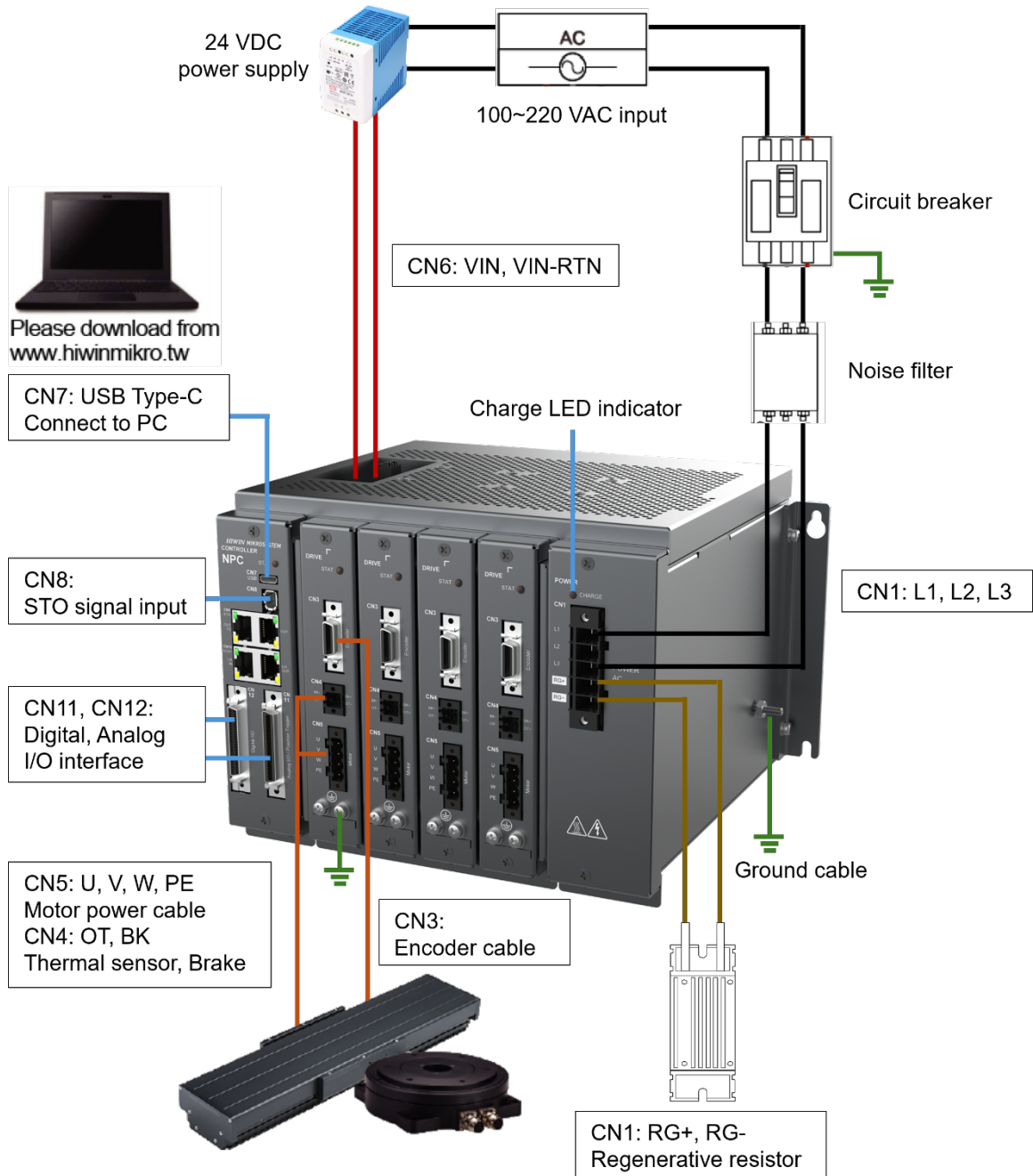



Figure 3.2.1.2 NPC-X-A□-A□ series

### 3.2.2 Power terminals and connectors

Table 3.2.2.1

NPC model	CN1 European type		CN5 European type	CN6 European type	Frame R type, M4
	DC+, DC- / L1, L2, L3	RG+, RG-	U, V, W, PE	+24V, 0V	
NPC-X-A□-D□ series	8 AWG /300V	12 AWG /300V	14 AWG /300V	22 AWG /300V	8 AWG /300V
NPC-X-A□-A□ series	8 AWG /600V	8 AWG /600V	16 AWG /600V	22 AWG /600V	8 AWG /600V

Note:

This table shows the maximum wire size that the connector can accommodate. The appropriate wire size should be selected based on the motor's rated current and power supply specifications.

■ Suggested configuration specification and tool for connectors

Table 3.2.2.2

Specification	Connector	Terminal Length (mm)	Screwdriver Specification
DC / AC power module	CN1	8	Phillips (M3)
DC / AC drive module	CN4	8	Slotted (M2.5)
	CN5	12	Slotted (M2.5)
Control module	CN6	12	Slotted (M2.5)

### 3.3 Wiring for power supply (CN1, CN6)

Wirings for main circuit power supply and control circuit power supply are described below.

**⚠ WARNING**



- ◆ Wiring must be correctly performed by referring to this section. Incorrect wiring may cause product malfunction and fire.

**⚠ CAUTION**



- ◆ Wiring or examination must be performed by professional technician.
- ◆ The power must be turned off before wiring or examination to avoid short circuit or electric shock.
- ◆ The residual voltage inside NPC could still be high after power off. Wiring should be performed five minutes after power off and the indicator goes off.

#### 3.3.1 Terminal symbols and terminal names

- CN1 (NPC-X-A□-D□ series)

**⚠ DANGER**

- ◆ Please be sure to use certified power supply with SELV output or certified power supply providing double insulation, LE (limited Energy circuits), LPS, or Class 2 evaluated by UL60950-1, UL 62368-1, or UL61010-1 and UL61010-2-201 standards.

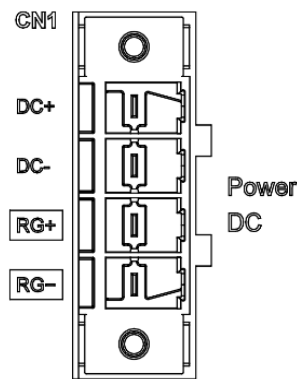



Figure 3.3.1.1

Table 3.3.1.1

Terminal Symbol	Function	Description
DC+, DC-	DC main power input terminals	DC 24 V ~ 100 V main power input. Note: It is recommended to use MEANWELL CSP-3000-120 power supply.

Terminal Symbol	Function	Description
RG+, RG-	Terminals for regenerative resistor	When the regenerative resistor is too high, connect to external regenerative resistor.
	Terminals for frame grounding	Single point connection to the ground.

■ CN1 (NPC-X-A□-A□ series)

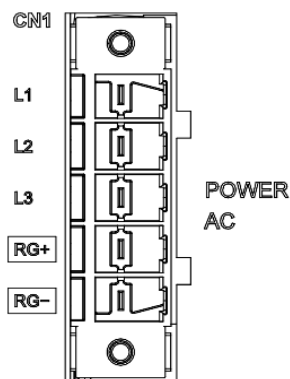



Figure 3.3.1.2

Table 3.3.1.2

Terminal Symbol	Function	Description
L1, L2, L3	AC main power input terminals	Single-phase AC 100 V ~ 240 V, 50/60 Hz main power input. Three-phase AC 200 V ~ 240 V, 50/60 Hz main power input.
RG+, RG-	Terminals for regenerative resistor	When the regenerative resistor is too high, connect to external regenerative resistor.
	Terminals for frame grounding	Single point connection to the ground.

■ CN6

 **DANGER**

◆ Please be sure to use certified power supply with SELV output or certified power supply providing double insulation, LE (limited Energy circuits), LPS, or Class 2 evaluated by UL60950-1, UL 62368-1, or UL61010-1 and UL61010-2-201 standards.

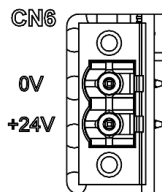

Figure 3.3.1.3

Table 3.3.1.3

Terminal Symbol	Function	Description
+24V	DC control power input terminals	DC 24 V control power input.
0V		

Note:

The 24 VDC power supply must be rated at 3 A or above. Supply power independently to the control module.

### 3.3.2 Wiring for regenerative resistor

This section will describe how to connect to regenerative resistor.

 **WARNING**



- ◆ Wiring must be correctly performed by referring to this section. Incorrect wiring may cause product malfunction and fire.

- Connection to external regenerative resistor

Connect to external regenerative resistor via RG+ and RG- terminals of NPC's power module.

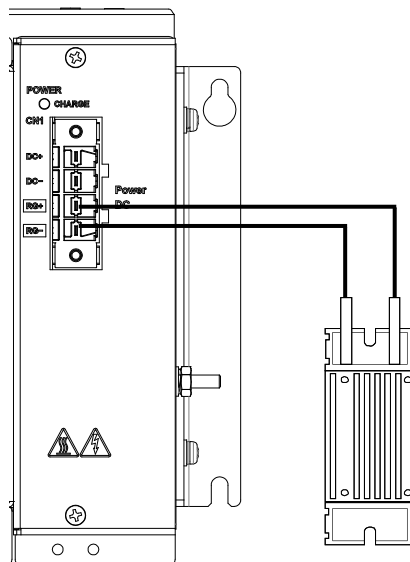

Figure 3.3.2.1 NPC-X-A-D series

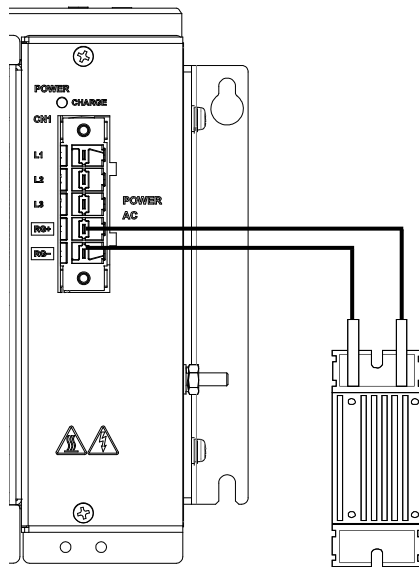

Figure 3.3.2.2 NPC-X-A□-A□ series

■ Minimum resistance of NPC external regenerative resistor

Table 3.3.2.1

NPC	DC series	AC series
Minimum Allowable Resistance of External Regenerative Resistor [Ω]	6.3	13

**Important Reminders**

- Pt600 (Regenerative resistor capacity) and Pt603 (Resistance of regenerative resistor) must be correctly set. Otherwise, regenerative protection may not be activated and AL.320 (Regenerative energy overflow) may not be detected. This may cause damage to the regenerative resistor, injury, or fire.
- Ensure the capacity of regenerative resistor is suitable. The installation site must be with well ventilation and heat dissipation. If not, this may cause regenerative resistor burn-out, injury or fire.

### 3.4 Wiring for servo motor

#### 3.4.1 Terminal symbols and terminal names

The terminals and connectors used for connecting drive module and servo motor are listed in the table below.

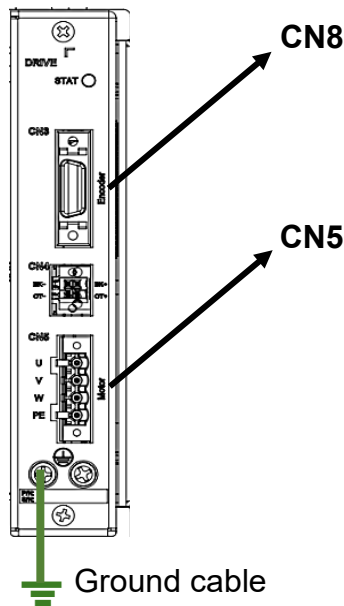

Figure 3.4.1.1

Table 3.4.1.1

Terminal/Connector Symbol	Terminal/Connector Name	Description
CN5	Motor power connector	While using HIWIN motor power cable, connect to the terminals on CN5 by referring to the symbols indicated on the cable.
	R type ground terminal	When the motor ground terminal is R type, please make sure it is firmly connected to the ground screw on the drive module frame.
CN8	Encoder connector	Connect to encoder cable.

Note:

For different power cables, there are two types of ground terminal: R type or European type. Please choose one of the two types for connection.

### 3.4.2 Motor power connector (CN5)

The terminals used for connecting drive module and motor are listed in the table below.

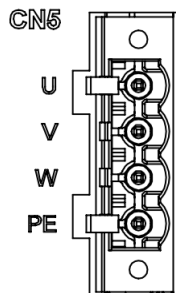



Figure 3.4.2.1

Table 3.4.2.1

Terminal Symbol	Function	Description
U	U phase power supply terminal	When using HIWIN motor power cable, connect to the corresponding terminals by referring to the symbols indicated on the cable. While using voice coil motor, connect to U and W phase power supply; do not connect to V phase power supply.
V	V phase power supply terminal	
W	W phase power supply terminal	
PE	Motor grounding	

Note:

If the motor ground cable is R type, please lock it to the ground symbol  on the frame.

### 3.4.3 Encoder connector (CN3)

The encoder connector and its pin definition are shown as follows. It supports linear motor and also rotary motor with digital encoder or analog encoder. Digital Hall sensor signal, thermal sensor signal, and single-ended digital encoder alarm signal are also included.

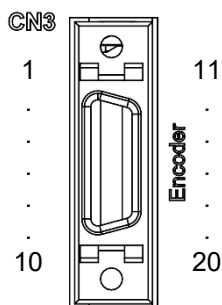

Figure 3.4.3.1

Table 3.4.3.1

Pin	Signal	Description
1	FG	Frame grounding and shield
2	SG	Signal ground
3	+5VE	Encoder power
4	ENC_A+	Digital differential signal input: A+ BiSS-C/EnDat serial clock input: MA+ / CLC+
5	ENC_A-	Digital differential signal input: A- BiSS-C/EnDat serial clock input: MA- / CLC-
6	ENC_B+	Digital differential signal input: B+ BiSS-C/EnDat serial clock input: SLO+ / DATA+
7	ENC_B-	Digital differential signal input: B- BiSS-C/EnDat serial clock input: SLO- / DATA-
8	ENC_IND+ / Ref+	Digital differential signal reference point input: Index+ / Analog differential signal input: Ref+
9	ENC_IND- / Ref-	Digital differential signal reference point input: Index- / Analog differential signal input: Ref-
10	SG	Signal ground
11	HA	Digital Hall sensor input: A
12	HB	Digital Hall sensor input: B
13	HC	Digital Hall sensor input: C
14	E- / PS+	Digital encoder differential alarm signal: E- / Serial signal: PS+
15	E+ / PS-	Digital encoder differential alarm signal: E+ / Serial signal: PS-
16	SIN+	Analog differential signal input: SIN+
17	SIN-	Analog differential signal input: SIN-
18	COS+	Analog differential signal input: COS+
19	COS-	Analog differential signal input: COS-
20	SG	Signal ground

**Important Reminders**

- If encoder cables used are not from HIWIN, please make sure they are anti-interference cables with shields.
- Please make sure the outer shield is firmly connected with the frame and FG signal.
- Please do not connect outer shield with inner shield and SG signal.

### 3.4.4 Wiring for brake (CN4, BK)

The terminals used for connecting drive module and motor brake / thermal sensor are listed in the table below.

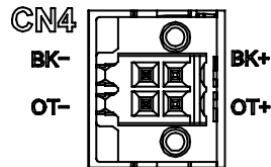

Figure 3.4.4.1

Table 3.4.4.1

Terminal Symbol	Function	Description
BK+	Connect to brake circuit	Connect to motor brake with relay.
BK-		

■ The wiring when brake is used with relay

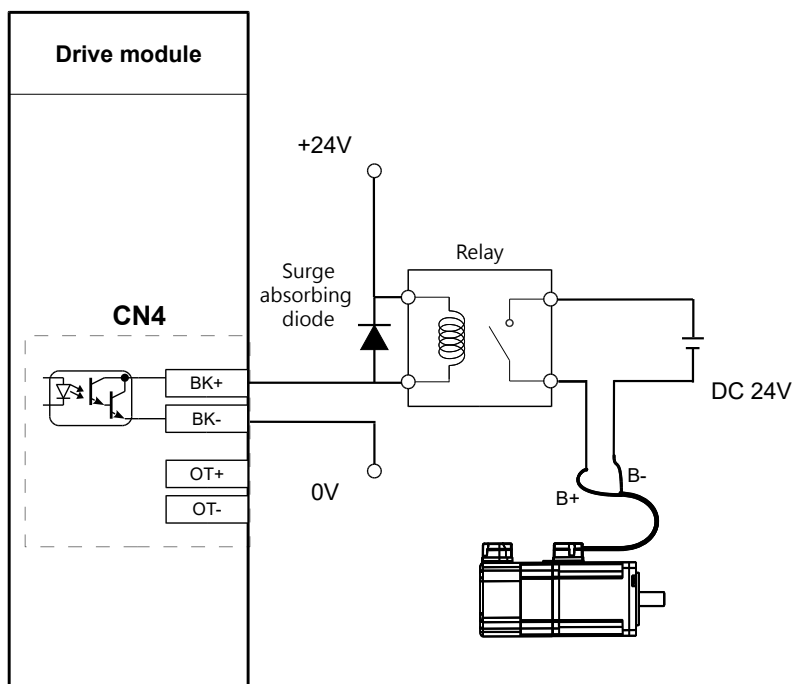

Figure 3.4.4.2

**Important Reminders**

- While using brake, DC 24 V for brake and power for I/O signals (CN11, CN12) must not share the same power supply to avoid false operation.
- Use relay which has built-in surge absorbing diode or add surge absorbing diode by yourself to avoid digital output burn-out.

### 3.4.5 Motor thermal sensor connector (CN4, OT)

When a motor includes a thermal sensor, it can connect to this connector to detect motor over-heating.

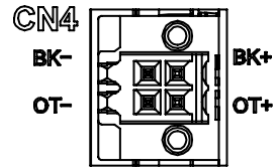

Figure 3.4.5.1

Table 3.4.5.1

Terminal Symbol	Function	Description
OT+	Detect thermal sensor signal	Connect to motor PTC thermal sensor.
OT-		

**Note:**

There is no polarity for thermal sensor signals. The supported thermal sensor is positive temperature coefficient (PTC) thermistor.

### 3.5 I/O signals (CN11, CN12)

#### 3.5.1 I/O signal connector

Please perform wiring according to the I/O signals in use. The pin definition is provided in the table below.

- Control module (CN11, 50 pin)

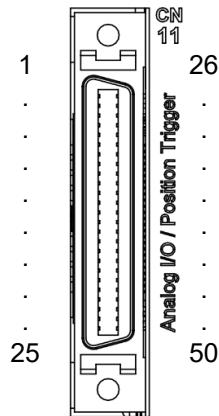

Figure 3.5.1.1 Pin definition of CN11

Table 3.5.1.1 CN11 – I/O signal pin definition

Category	Pin	Signal	Description
Position Trigger Output	1	PT1+	For the wiring of high-speed position trigger output function.
	2	PT1-	
	3	PT3+	
	4	PT3-	
	5	PT5+	
	6	PT5-	
	7	PT7+	
	8	PT7-	
	9	PT9+	
	10	PT9-	
	26	PT2+	
	27	PT2-	
	28	PT4+	
	29	PT4-	
	30	PT6+	
	31	PT6-	
32	PT8+		
33	PT8-		
34	PT10+		

Category	Pin	Signal	Description
	35	PT10-	
Analog Input	12	AI1+	Differential analog inputs (+/-10 V).
	13	AI1-	
	14	AI3+	
	15	AI3-	
	16	AI5+	
	17	AI5-	
	18	AI7+	
	19	AI7-	
	37	AI2+	
	38	AI2-	
	39	AI4+	
	40	AI4-	
	41	AI6+	
	42	AI6-	
	44	AI8+	
44	AI8-		
Analog Output	20	AO1+	Differential analog outputs (+/-10 V).
	21	AO1-	
	22	AO3+	
	23	AO3-	
	24	AO5+	
	25	AO5-	
	45	AO2+	
	46	AO2-	
	47	AO4+	
	48	AO4-	
	49	AO6+	
	50	AO6-	
Grounding	11	SG	Signal ground.
	36	ASG	

■ Control module (CN12, 50 pin)

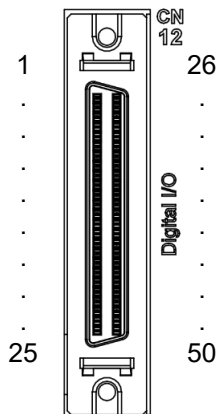

Figure 3.5.1.2 Pin definition of CN12

Table 3.5.1.2 CN12 – I/O signal pin definition

Category	Pin	Signal	Description
Digital Input	1	COM	Common point for digital signal inputs.
	2	I1	General-purpose input signals. Users are allowed to use the default setting or configure input functions by themselves.
	3	I3	
	4	I5	
	5	I7	
	6	I9	
	7	I11	
	8	I13	
	9	I15	
	10	I17	
	11	I19	
	12	I21	
	13	I23	
	26	I2	
	27	I4	
	28	I6	
	29	I8	
	30	I10	
	31	I12	
	32	I14	
33	I16		
34	I18		
35	I20		
36	I22		
37	I24		

Category	Pin	Signal	Description
Digital Output	14	O1+	General-purpose output signals. Users are allowed to use the default setting or configure output functions by themselves.
	15	O1-	
	16	O3+	
	17	O3-	
	18	O5+	
	19	O5-	
	20	O7+	
	21	O7-	
	38	O2+	
	39	O2-	
	40	O4+	
	41	O4-	
	42	O6+	
	43	O6-	
44	O8+		
45	O8-		
High-Speed I/O	22	FIO1+	High-speed inputs and outputs, RS-485 differential signaling.
	23	FIO1-	
	24	FIO3+	
	25	FIO3-	
	46	FIO2+	
	47	FIO2-	
	48	FIO4+	
49	FIO4-		
Grounding	50	SG	Signal ground.

### 3.5.2 Wirings for inputs and outputs

■ Wiring for digital inputs

Digital input signal is input via optical coupler. The external power could be 5~24 VDC. The wiring could be sink or source type. Digital input functions can be user-defined.

(1) Wiring for digital inputs (Sink) (Switch or transistor)

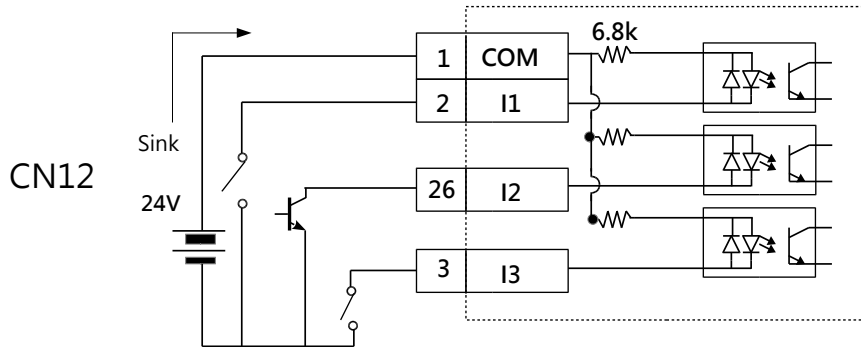

Figure 3.5.2.1

(2) Wiring for digital inputs (Source) (Switch or transistor)

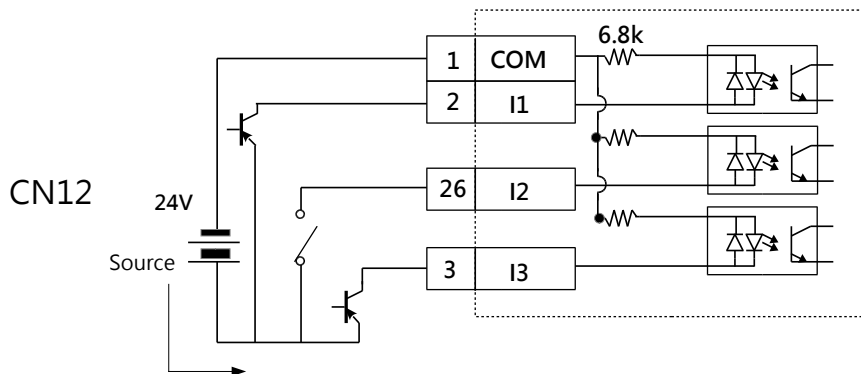

Figure 3.5.2.2

■ Wiring for digital outputs

Digital output signal is output via optical coupler. The external power must not exceed 24 VDC. The digital outputs are independent open-collector outputs. The maximum allowable current is 100 mA. Digital output functions can be user-defined.

Wiring for digital outputs (Relay or optical coupler)

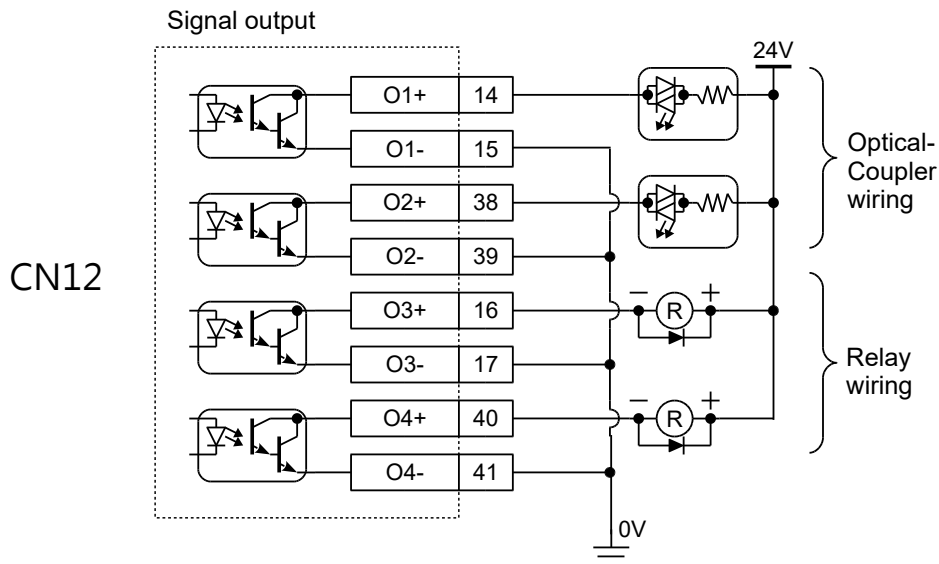

Figure 3.5.2.3

■ Wiring for analog inputs and outputs

Analog inputs and outputs are used to monitor motor torque, velocity, feedforward, or other applications (such as auto focus and force control). The voltage range is differential  $\pm 10$  V.

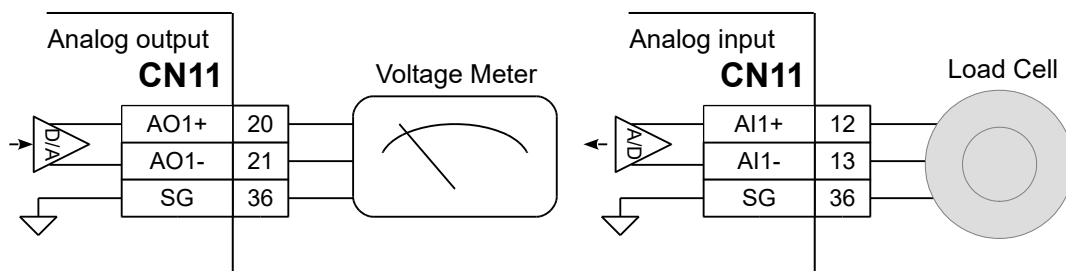

Figure 3.5.2.4

- Position trigger (PT) output signal  
Enable or disable position trigger output function by the parameter.

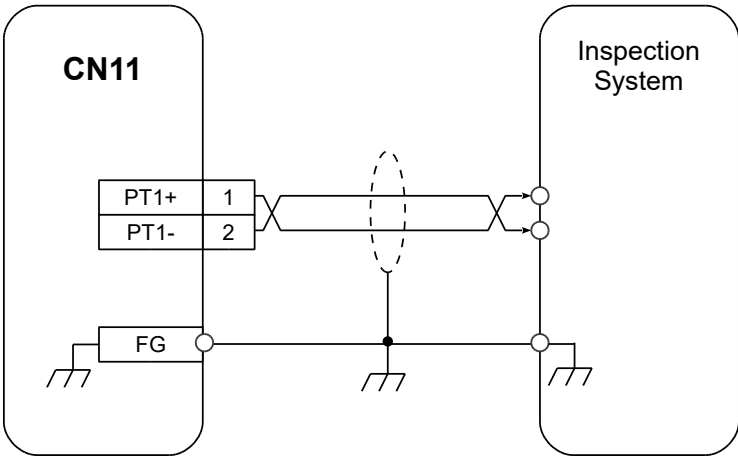

Figure 3.5.2.5

### 3.6 STO connector (CN8)

#### 3.6.1 Pin definition of STO connector

Before using STO safety function, pay attention to the pin definition. If STO safety function is not used, plug the safety jumper connector provided with NPC into CN8. If it is not plugged in, NPC will not output current to the motor.

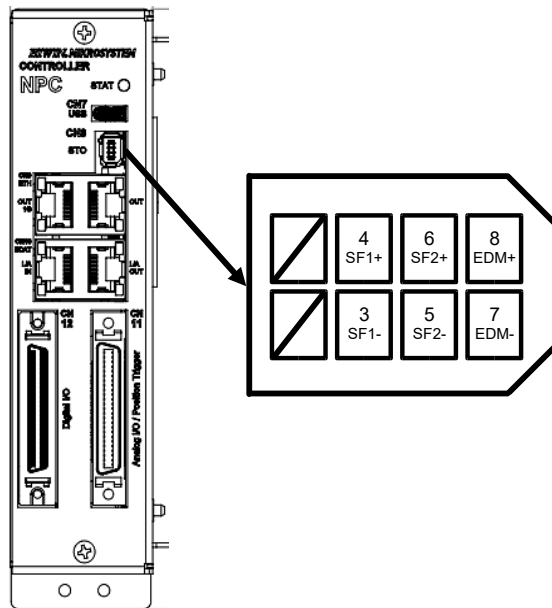

Figure 3.6.1.1

Table 3.6.1.1

Pin	Function	Description
1	Reserved	Do not use.
2		
3	SF1-	SF1 and SF2 signals are input via two independent circuits. If SF1 and SF2 signals are not input, the internal power module of NPC will be shut down to cut off the output current.
4	SF1+	
5	SF2-	
6	SF2+	
7	EDM-	Monitors if safety function is normal.
8	EDM+	
Shield	FG	Frame ground.

### 3.6.2 Wiring for STO safety function

- Wiring for STO safety function

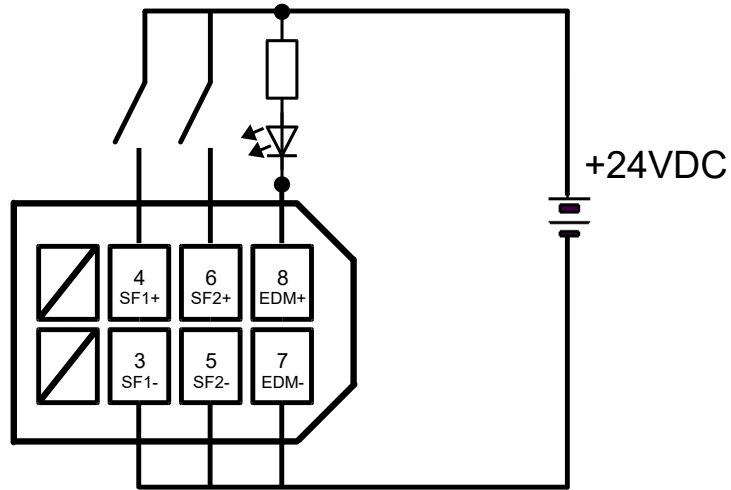

Figure 3.6.2.1

- Wiring example for STO safety function

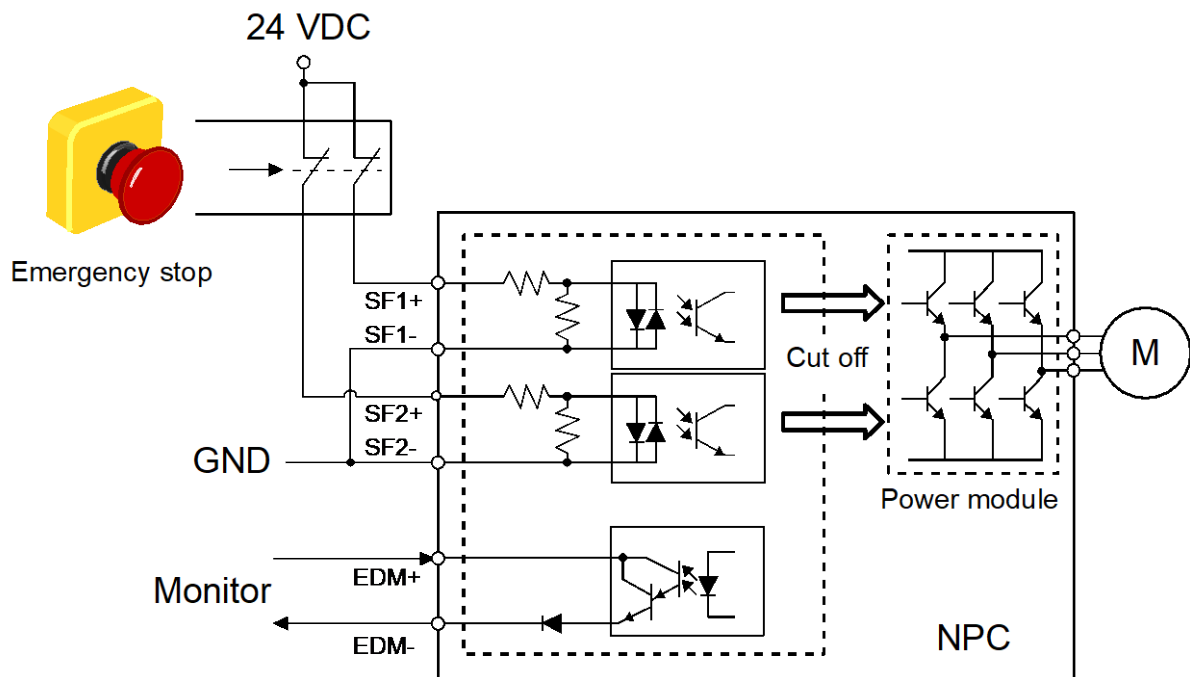

Figure 3.6.2.2

### 3.7 Communication connectors

#### 3.7.1 Connector for PC communication (CN7)

Use USB Type-C cable to connect to PC by CN7 for monitoring, trial operation or parameter setting.

#### 3.7.2 Connector for Fieldbus communication (CN10)

If Fieldbus control module is used, connect to CN10 via metal shielded RJ-45 connector and Ethernet communication cable. The communication cable must be CAT-5 or above.

There are two communication ports on CN10, OUT port and IN port, please refer to below.

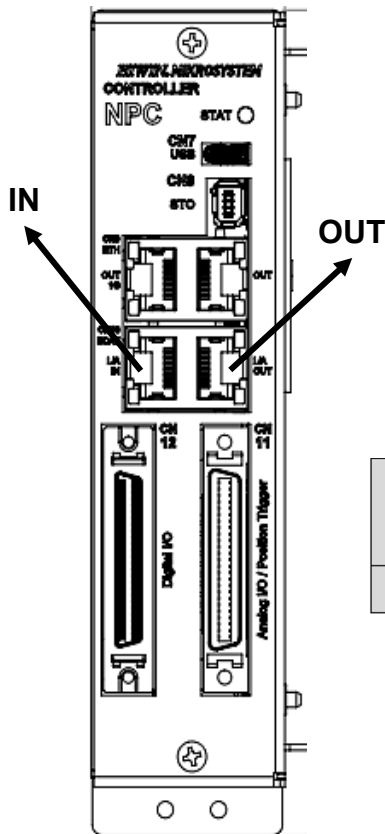

OUT	Connect to the IN port on other EtherCAT servo drive or other slave. If NPC is the last station, do not connect to this port.
IN	Connect to third party EtherCAT controller (master).

Figure 3.7.2.1

### 3.7.3 Connector for API library communication (CN9)

If API library is used, connect to CN9 via metal shielded RJ-45 connector and Ethernet communication cable. The communication cable must be CAT-5 or above.

There are two communication ports on CN9, ETH 1G port and ETH 100M port, please refer to below.

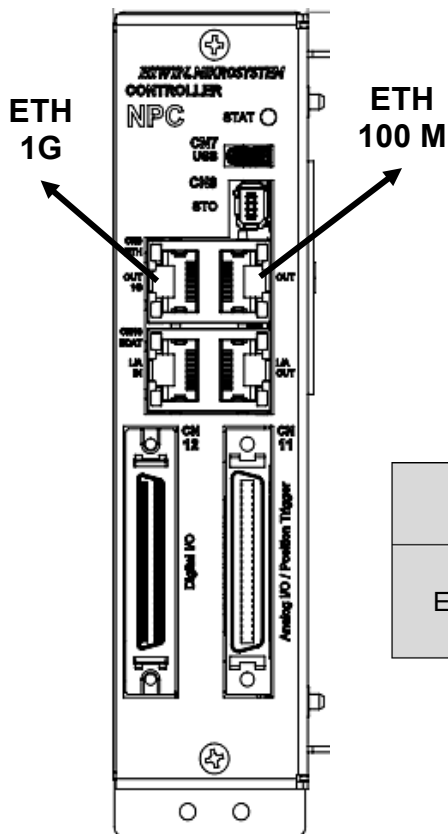

ETH 1G	Connect to Host PC for API. (Fixed IP address: 192.168.0.100)
ETH 100M	Connect to Host PC for API or other HIWIN servo drive with mega-ulink. (Fixed IP address: 192.168.0.101)

Figure 3.7.3.1

(This page is intentionally left blank.)

## 4. Appendix

---

4. Appendix.....	4-1
4.1 Maintenance.....	4-2
4.1.1 Regular inspection.....	4-2
4.1.2 Replacement standard .....	4-2
4.2 Accessories .....	4-3
4.2.1 Accessory kit .....	4-3
4.2.2 Selection of system peripherals .....	4-4

## 4.1 Maintenance

### 4.1.1 Regular inspection

NPC does not need to be inspected daily, but the items listed in the table below must be inspected every half year or annually.

Table 4.1.1.1

Item	Frequency	Inspection	Corrective Action
Appearance and Environment	Half year or annually	No litter, dust, oil and stain, etc.	Clean the environment and NPC.
Screws		Parts must be tightened, such as terminal block, connector and screw, etc.	Tighten the parts with screw driver.

### 4.1.2 Replacement standard

The electronic parts inside NPC are subject to mechanical wear or deterioration. The table below provides the replacement standards for the electronic parts.

Table 4.1.2.1

Part	Replacement Standard	Note
Fan	4~5 years	<ul style="list-style-type: none"> <li>Ambient temperature: average 30°C</li> <li>Operation time: 20 hours/day</li> </ul>
Electrolytic Capacitor	2 years	
Relay	Power on for 30,000 times.	Frequency: 1 time/hour
Battery	2.5 years (No power is supplied.)	Storage temperature: 20°C

When replacement standard is met, contact HIWIN MIKROSYSTEM or our distributors to check if replacement is required.

## 4.2 Accessories

### 4.2.1 Accessory kit

The accessory kit of NPC is optional. For the contents inside the accessory kit, please refer to the tables below.

Table 4.2.1.1 Accessory kit for DC power

Name	HIWIN Part Number	Description	Qty.
NPC CK1 accessory kit (For DC power)	180600100020	CN1: DC main power input, connect to external regenerative resistor (Brand: DINKLE, Specification: EC762HVM-04P-BK)	1
		CN6: Control power input (Brand: DINKLE, Specification: 2ESSM-02P-BK)	1

Table 4.2.1.2 Accessory kit for AC power

Name	HIWIN Part Number	Description	Qty.
NPC CK2 accessory kit (For AC power)	180600100021	CN1: AC main power input, connect to external regenerative resistor (Brand: DINKLE, Specification: EC762HVM-05P-BK)	1
		CN6: Control power input (Brand: DINKLE, Specification: 2ESSM-02P-BK)	1

Table 4.2.1.3 Accessory kit for drive module

Name	HIWIN Part Number	Description	Qty.
NPC CK3 accessory kit (General use)	180600100022	CN4: Motor brake signal detection, motor thermal sensor signal detection (Brand: DINKLE, Specification: 0156-2A04-BK)	1
		CN5: Motor power output, motor grounding (Brand: DINKLE, Specification: 2ESSM-S1629704P)	1

## 4.2.2 Selection of system peripherals

### ■ Leakage breaker (Optional)

Table 4.2.2.1 DC power supply

Applicable Axes	Name	HIWIN Part Number	Description
4, 6, 8	Leakage breaker	920302500026	Model: EW63RAG-3P060K Frame size: 63 AF Rated current: 60 A Rated sensitivity current: 100/200/500 mA changeover

Table 4.2.2.2 AC single-phase / three-phase power supply

Applicable Axes	Name	HIWIN Part Number	Description
4, 6	Leakage breaker	920302500025	Model: EW50RAG-3P040K Frame size: 50 AF Rated current: 40 A Rated sensitivity current: 100/200/500 mA changeover
8	Leakage breaker	920302500026	Model: EW63RAG-3P060K Frame size: 63 AF Rated current: 60 A Rated sensitivity current: 100/200/500 mA changeover

Note:

If leakage breaker is used, ensure it meets the following specifications to prevent false operation:

- (1) Sensitivity current: Above 200 mA
- (2) Operating time: Above 100 ms

■ Fuse accessory kit (Optional)

Table 4.2.2.3 DC power supply

Applicable Axes	Name	HIWIN Part Number	Description
4, 6, 8	Fuse accessory kit	180600600010	Fuse: JLLN060.T, Class T 300 Vac / 60 A / Fast-Acting, Qty: 3 Fuse holder: LFT300603C, Class T 300 Vac / 60 A, Qty: 1 Fuse stand cover: LFT30060FBC, Qty:3

Table 4.2.2.4 AC single-phase / three-phase power supply

Applicable Axes	Name	HIWIN Part Number	Description
4, 6	Fuse accessory kit	180600600009	Fuse: JLLN040.T, Class T 300 Vac / 40 A / Fast-Acting, Qty: 3 Fuse holder: LFT300603C, Class T 300 Vac / 60 A, Qty: 1 Fuse stand cover: LFT30060FBC, Qty:3
8	Fuse accessory kit	180600600010	Fuse: JLLN060.T, Class T 300 Vac / 60 A / Fast-Acting, Qty: 3 Fuse holder: LFT300603C, Class T 300 Vac / 60 A, Qty: 1 Fuse stand cover: LFT30060FBC, Qty:3

Note:

For UL certification, fuse accessory kit is required.

■ Power supply filter (Optional)

Table 4.2.2.5 DC / AC single-phase power supply

Applicable Axes	Name	HIWIN Part Number	Description
4, 6, 8	Filter	920301400007	Model: FN2010-60-24 Rated current: 60 A Leakage current: 0.79 mA

Table 4.2.2.6 AC three-phase power supply

Applicable Axes	Name	HIWIN Part Number	Description
4, 6	Filter	920301400010	Model: FN3270HQ1-35-33 Rated current: 35 A Leakage current: 0.4 mA
8	Filter	920301400020	Model: FN3270HQ1-50-34 Rated current: 50 A Leakage current: 0.4 mA

■ DC power supply (Optional)

Table 4.2.2.7

Applicable Axes	Name	HIWIN Part Number	Description	Recommended Quantity
1~4	Power supply	920301700018	Model: CSP-3000-120 Input voltage range: 180 ~ 264 Vac Output voltage range: 18 ~ 120 Vdc Output current range: 0 ~ 25 A	1 set or 2 sets (parallel)
4~8				2 sets (parallel)

Note:

The recommended quantity depends on whether the axes are simultaneously outputting maximum motion.

If all four axes are simultaneously outputting maximum peak value, it is recommended to use 2 sets in parallel.

■ Regenerative resistor (Optional)

Table 4.2.2.8

Name	HIWIN Part Number	Description
Regenerative resistor	050100700001	Resistance: 68 Ohms Power: 100 W
Regenerative resistor	050100700031	Resistance: 190 Ohms Power: 1000 W

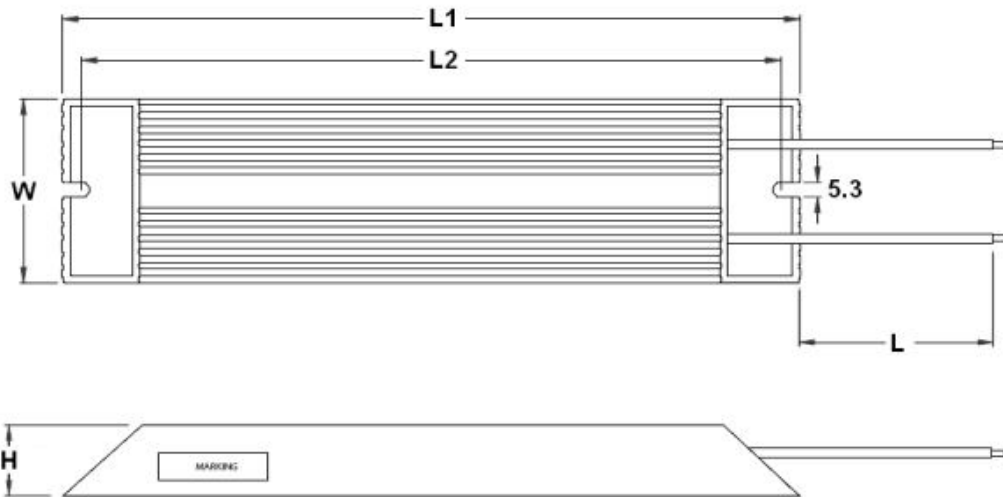

Figure 4.2.2.1 Dimension of regenerative resistor 050100700001

For cable length, please refer to below:

Table 4.2.2.9

	L	L1±2	L2±2	W±0.5	H±0.5
Cable Length (mm)	500	165	150	40	20

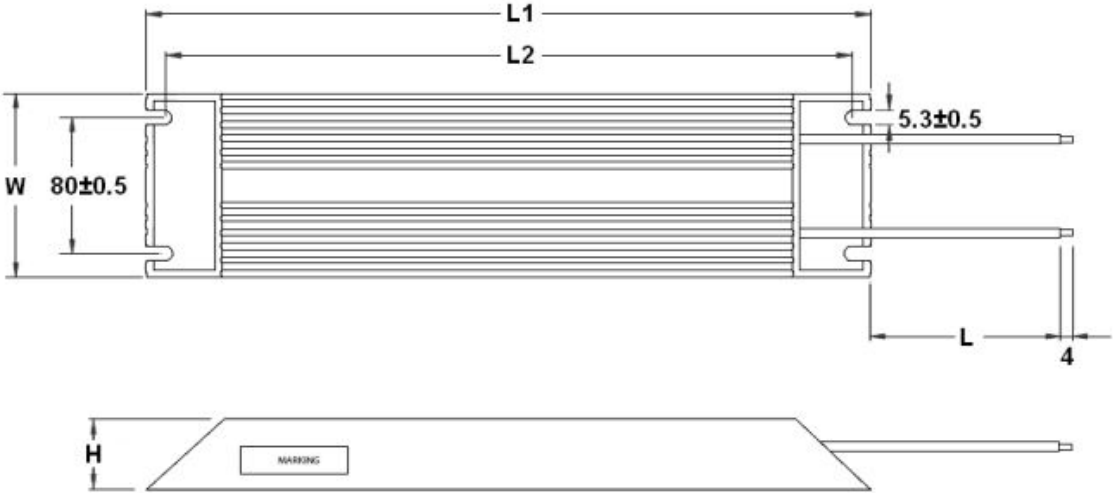

Figure 4.2.2.2 Dimension of regenerative resistor 050100700031

For cable length, please refer to below:

Table 4.2.2.10

	L	L1±2	L2±2	W±1	H±1
Cable Length (mm)	200±20	400	385	100	50